



# SPRINTER VAN EQUIPMENT



TS/ISO Registered



# ADRIAN STEEL®

*Cargo Management Solutions for Commercial Vehicles*



# PLAN YOUR VAN

## YOU HAVE COME TO THE RIGHT PLACE FOR ORGANIZING YOUR SPRINTER CARGO VAN.

Adrian Steel has all the storage products you will need, and the tools to put them all together to best utilize the space in your Sprinter. This catalog is set up to walk you through the product categories as you would add them into your vehicle. Follow these simple steps to create an interior that fits your needs:

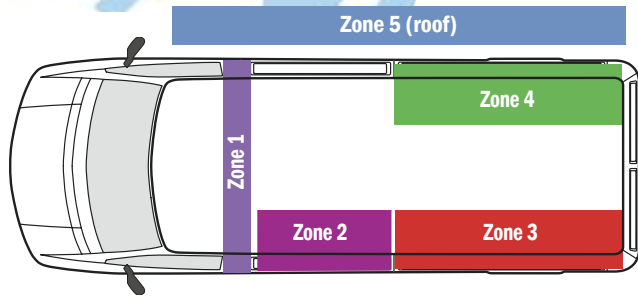

### Zone 1 Partition

- Choose partition style: solid, perforated, or with a hinged door.
- Determine Sprinter roof height.
- Check chart on page 3 for vehicle fit.
- Add accessories on both cab and cargo side from page 3.
- **I need:**

### Zones 2, 3, 4 Curbside & Streetside

- Use layout diagrams at right to determine the amount of space available.
- Choose from a variety of shelving units and modules that will best organize the tools and equipment you need to carry.
- **I need:**

### Zone 5 Roof

- Determine what will be carried: ladders, sheet goods, conduit, etc.
- Choose the LoadsRite for specifically carrying ladders.
- VP Perimeter and 3-BAR Cargo Racks can carry a variety of cargo and ladders.
- Add rack accessories including step ladder kits, ratchet straps, conduit carriers and more.
- **I need:**

### Additional Storage

- Determine the space needed for specialty equipment: tank racks, lockers, reel holders, Stow-All floor drawers and more.
- Add accessories including door kits, drawer units, hooks and more.
- **I need:**

### 144" Wheelbase Sprinter interior layout guide 2007-on

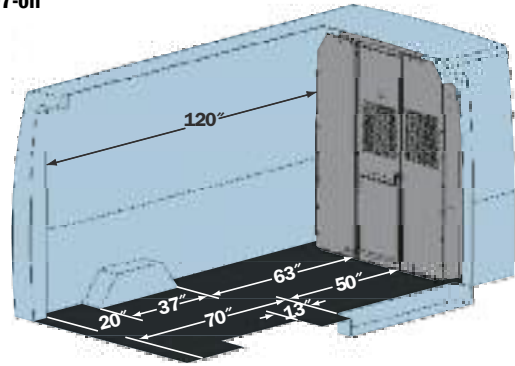

### 170" Wheelbase Sprinter interior layout guide 2007-on

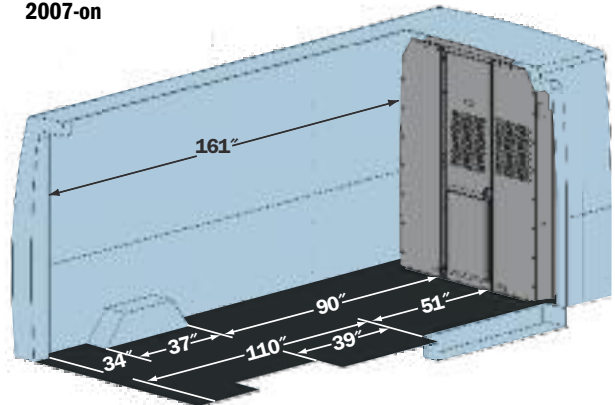

### 170" Extended Wheelbase Sprinter interior layout guide 2007-on

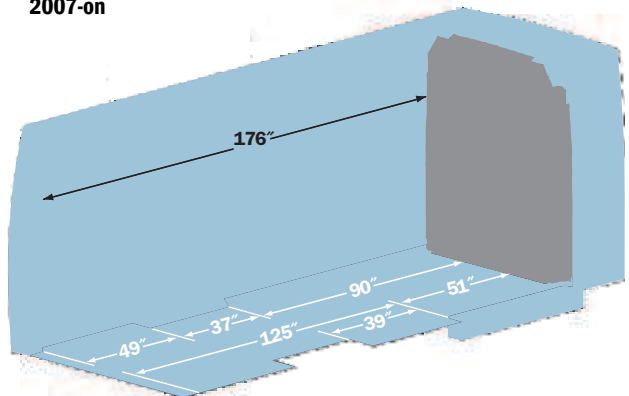

If you are still drawing a blank as to where to start, browse through the trade packages on pages 8-11. Contact your local distributor, they will be able to provide a wealth of information about best utilizing the space in your vehicle. They will also provide pricing and professional installation by Adrian Steel Certified installers. Visit [adriansteel.com](http://adriansteel.com) to find your local distributor.

Note: Dimensions for reference only. Measure your van or contact your distributor for your exact needs.

# PARTITIONS

**PROTECTION FOR CARGO. PROTECTION FROM CARGO.** Adrian partitions provide security from shifting loads. Choose a perforated partition for visibility or solid for better climate control. Solid and hinged door partitions are available.

## Features & Benefits

- Built of strong, 16-gauge steel.
- Formed channels for extra strength.
- Steel-Cote™ diamond-hard finish resists scratches and dents
- Perforated partition panels are strong and quiet.
- Includes all assembly and installation fasteners for base van trim level.  
Higher trim levels may require modifying trim or partition.
- Partition features lower access holes for electrical wiring.

## Adrian's accessories fully utilize your partition space.

- Make locating your equipment easy.
- Practical item storage. For everyday materials.
- For miscellaneous or required safety equipment.
- For increased partition security.

Adrian's Sprinter partition is designed to give you more leg room.

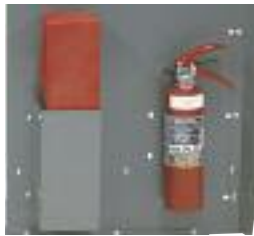

### Vehicle Safety

#### PA7 Triangle Reflector Kit

#### PA8 1-A:10-BC Fire Extinguisher



### Tank Holders

#### TH30 Refrigerant Tank Holder 30 lb

#### TH50 Refrigerant Tank Holder 50 lb.



#### PA9 First Aid Box Tray

secures first aid box to partition or other vertical surface.

Overall size: 9" W, 3-1/2" H, 3" D.



#### PA6-2 Door Kit

converts M-Series fixed center panel into hinged door with keyed handle.



#### TA1 Hook Bar

2" X 12" with 2" hanger opening. Mounts to any vertical surface



#### PA10 Practice Holder

Partition mounted holder for forms, manuals or work related papers

Overall size: 12" W, 7" H, 5" D.



#### PA11 Cab File Box

mounts to partition or other vertical surface.

Overall size: 14" W, 10-1/2" H, 3-1/2" D.



#### CB2 Two Book File

has hinged retaining straps. Mounts to floor or other horizontal surface.

Overall size: 6" W, 14" H, 9 3/4" D.

## 2007 and newer Sprinter Van Partition Panel Styles

Please state Sprinter model, year and wheelbase when ordering.

Model	Roof Type	Streetside		Center			Curbside	
		Solid	Perforated	Solid	Hinged	Perforated	Solid	Perforated
				Fixed	Fixed	Hinged		
S1M1C1SPS	standard	■		■			■	
S1M1HC1SPS	standard	■			■		■	
S1M2C1SPS	standard	■			■		■	
S1M2HC1SPS	standard	■				■	■	
S1M2C2SPS	standard	■			■			■
S1M2HC2SPS	standard	■				■	■	■
S2M2C2SPS	standard		■		■			■
S2M2HC2SPS	standard		■			■	■	■
S1M1C1SPH	high	■		■			■	
S1M1HC1SPH	high	■			■		■	
S1M2C1SPH	high	■			■		■	
S1M2HC1SPH	high	■				■	■	
S1M2C2SPH	high	■			■			■
S1M2HC2SPH	high	■				■	■	■
S2M2C2SPH	high		■		■			■
S2M2HC2SPH	high		■			■	■	■
PA5-2 Plexiglas Cover Panel			■		■	■		■

Please note: Contact Adrian Steel for 2006 and older Sprinter partitions.

Please note: 170" interior installed in a Mega High roof Sprinter will require OEM partition.

See more partition images and accessories on-line at [adriansteel.com](http://adriansteel.com)



# DRAWER & CABINET MODULES

**MAXIMIZE STORAGE IN YOUR SPRINTER VAN!** A great way to show your professionalism is to have an organized van. Get everything off the floor and in its place with storage modules and accessories from Adrian Steel. Designed to accommodate a variety of items, with a combination of shelving, drawers, cabinets, files and more.

Modules come complete with installation instructions and fasteners. Some drilling is required. Installation should always be made to a body frame member or reinforcement to the body for secure attachment.



**HD-SWP Series Adjustable Shelving** Contains a 12" deep top tray with a 2" lip, one 14" deep shelf with a 2" lip, and two 14" deep shelves with a 4" lip. Contoured end panels provide flush fit to van side to maximize aisle space. Shelf gussets and a full floor rail provide extra strength. Available in three widths:  
**HD-32SWP** 32" W, 56" H, 12"/14" D  
**HD-42SWP** 42" W, 56" H, 12"/14" D  
**HD-52SWP** 52" W, 56" H, 12"/14" D

**HD-SPR Adjustable Shelving** Contains 12" deep top shelf, one 14" deep HD shelf with drop in dividers and two 14" deep Z-shelves with removable shelf rail to add BasePlus accessories like drawers or door kits. Contoured end panels provide a flush fit. Available in three widths:  
**HD32SPR** 32" W, 56" H, 12"/14" D  
**HD42SPR** 42" W, 56" H, 12"/14" D  
**HD52SPR** 52" W, 56" H, 12"/14" D

**MD601 Drawer/Cabinet Module** Features two large lockable cabinets both with an adjustable shelf, and one 3-drawer combo with dividers.  
**Measures 18" W, 56" H, 12" D.**

**MD602 Drawer/Tray Module** features three lockable 3-drawer mediums and a parts tray on top with a 2" lip.  
**Measures 18" W, 56" H, 12" D.**

**MD603 Drawer/Cabinet Module** contains one large lockable cabinet with an adjustable shelf, one 3-drawer combo with a plastic parts tray in each of the two shallow drawers. One 3-drawer medium and a parts tray with a 2" lip for added storage.  
**Measures 18" W, 54" H, 12" D.**

**Locking Door Kits** for adjustable shelving **SPR Shelving:**  
**DK532SPR** 32" Door Kit with back panel  
**DK542SPR** 42" Door Kit with back panel  
**DK552SPR** 52" Door Kit with back panel

**SWP Shelving:**  
**DK532** 32" Door Kit with back panel  
**DK542** 42" Door Kit with back panel  
**DK552** 52" Door Kit with back panel

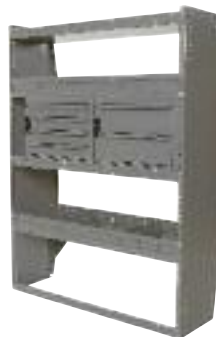

**MD604 Drawer/Cabinet Module** has four large lockable cabinets with adjustable shelves, and eight shallow drawers. Cabinets feature an open side and combine to form a 36" wide compartment. Each drawer contains dividers to organize small parts.  
**Measures 36" W, 56" H, 12" D.**

**MD605 Drawer/Cabinet Module** combines two open sided lockable cabinets with adjustable shelves, ten medium drawers and a large 36" parts tray with a 2" lip across the top.  
**Measures 36" W, 54" H, 12" D.**

**MD607 Heavy-Duty KD Storage Unit** features divided shelf storage, adjustable shelves, four shallow drawers with dividers in each, and two medium drawers.  
**Measures 42" W, 56" H, 12"/14" D.**

**MD609 Heavy-Duty KD Storage Unit** features two shelves with divided shelf storage and a 4" lip in addition to a lockable 52" long compartment.  
**Measures 52" W, 56" H, 12"/14" D.**

**MD705 Workbench Module** has a Masonite covered worktop, stool, eight shallow and six medium drawers. All fourteen drawers are lockable.  
**Measures 42" W, 32" H, 12"/18" D.**

**Vehicle fit** Modules will fit both Sprinter standard and high roof models. A minimum of 42" is needed to fit over all wheel-wells. 18" W and 36" W modules designed to fit either side of wheel-wells.  
**How to order** Please state Sprinter model, year and wheel base when ordering.



**MD610 Workbench Module** includes a heavy-duty steel workbench with a Masonite covered worktop, stool, nine lockable medium drawers, four locking shallow drawers, a catalog file and a lockable wheel-house cover.  
**Measures 84" W, 32" H, 12"/18" D.**

# ACCESSORIES



**Tote Trays and Cases**  
Measures 19-3/4"W x 20-1/8"H x 13-3/8"L.

Model	Description
SPT-4	Combo Totes and Rack Steel Trays (2) Poly Cases (2)
SPT-4P	Poly Totes and Rack Poly Cases (4)
SPT-4S	Steel Totes and Rack Steel Trays (4)



**Shelf Cabinets** can be used free standing or are perfect for stacking with our lockable drawer units.

Model	Description & Cabinet Size
1	Shelf Cabinet 18"W x 22"H x 18"L
12	Shelf Cabinet Open Side 18"W x 22"H x 12"L
1A	Optional Shelf for No. 1
12A	Optional End Panel for No.12

**Tank Racks** vertically carry 30-lb. and 50-lb. Refrigerant tanks. Racks feature 14-gauge tubular steel frames welded for strength with sloped cradles and nylon straps.

Model	Description
WTR130250	(1) 30 lb & (2) 50 lb tanks
WTR230150	(2) 30 lb & (1) 50 lb tanks
WTR330	(3) 30 lb tanks
WTR350	(3) 50 lb tanks
WTR430	(4) 30 lb tanks



WTR430

WTR130250

WTR230150



**Drawer Units – Lock n Latch System**  
18"W x 12"H x 12"L steel cabinet with composite drawers. Key locking.

Model	Desc. & Drawer Size (Qty.)
19	2 Drawer Medium 16" W x 5" D x 11-1/2" L (2)
919	3 Drawer Combo 16" W x 2-1/2" D x 11-1/2" L (2) 16" W x 5" D x 11-1/2" L (1)
9	4 Drawer Shallow 16" W x 2-1/2" D x 11-1/2" L (4)



CL1446D

CL1446R

**Cabinet Lockers**  
Lockers feature a 46" high storage space with removable shelves.

Model	Description & Cabinet Size
CL1446R	Cabinet Locker Full Door 18"W x 46"H x 14"D
CL1446D	Cabinet Locker Short Door 18"W x 46"H x 14"D

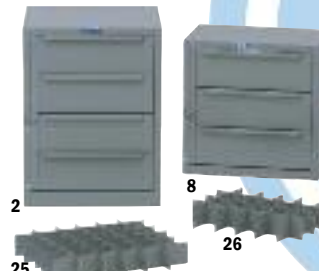

**Drawer Units – Locking Hinge & Hasp**  
#2 measures 18"W x 24"H x 18"L  
#8 measures 18"W x 18"H x 12"L

Model	Desc. & Drawer Size (Qty.)
8	3 Drawer Medium 16" W x 5" D x 11-1/2" L (3)
2	4 Drawer Medium 16" W x 5" D x 17-1/2" L (4)
25	Divider Kit for #2 Drawer (1)
26	Divider Kit for #8 Drawer (1)

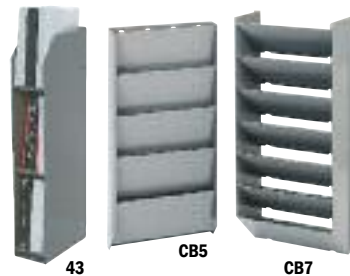

43

CB5

CB7

**43 Three Shelf Catalog File**  
Overall size: 6" W, 34" H, 12" D.

**CB5 Five Slot Literature Holder**  
Overall size: 12" W, 24" H, 2-1/2" D.

**CB7 Seven Slot Literature Holder**  
Overall size: 14-3/4" W, 28-7/8" H, 7" D.



**Drawer Components**  
High-impact polymer construction with drawer retention stops.

Model	Desc. & Cabinet Size
DC6	Base 3 drawer narrow model 6"W x 12"H x 12"D
DC12	Base 3 drawer wide model 12"W x 12"H x 12"D



**KDRH2 Cable Reel Holder** holds large spools up to 16" wide and 18" in diameter. Spools nest on conveyor rollers. Includes tie-down chains with neoprene covers.

Overall size: 18" W, 46" H, 18" D

**Wire Window Screens** add security to cargo area windows. Screens are available for street and curbside sliding doors and rear doors.

Model	Description
60-75	Curbside Sliding Door Window Screen
60-76	Streetside Sliding Door Window Screen
60-77	Curbside Rear Door Window Screen
60-78	Streetside Rear Door Window Screen

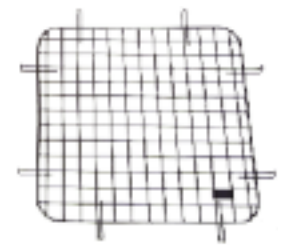

**CRH2 Cable Reel Holder** features a durable frame, two steel shafts that holds up to a 15-1/2" diameter reel by 14" wide. 19-1/8" W, 16" D, 44-7/8" H



**VMA36 Vise Mount Assembly** is floor mounted and telescopes out doors when fully opened. Measures 36" closed and 60" open.

Model	Description
UH10	1" hook
UH25	2-1/2" hook
UH50	5" hook
TA1	4 Hook Bar

# FLOOR STORAGE

## ADRIAN'S STOW-ALL IS THE FINEST FLOOR STORAGE UNIT YOU CAN BUY.

- 14 Gauge steel outer cabinets are constructed with top channel cross support members for strength and rigidity.
- Drawers are constructed with double sidewalls to prevent bowing and to accommodate items up to 48" in length.
- The anti-slam latch stops drawers from completely closing without positive latch activation.
- Heavy-duty grab handle and push button lock allows for comfortable, one-handed drawer operation.
- Durable baked-on powder coat finish will provide years of rugged service.
- Easy glide drawers with full width recessed conveyor roller at front. Hardened steel roller bearings at rear.
- Stow-Alls can be mounted at rear of door, at side door and can be stacked.
- Keeps expensive tools safe and secure.



- Anti-Slam Latch
- HD Grab Handle
- Push Button Lock



**Traction Kits** are available to provide a positive friction surface for better footing. Traction Kits come with 4" wide strips. **Additional Dividers** are available and sold individually.



SA-10



SA-20



SA-40

### Stow-All Deep Series

Model	Description	Cabinet Size	Drawer Size	Traction Kit	Divider (Qty.)
SA-10	Single Wide Deep	10"W x 12"H x 51-1/2"D	9-5/8"W x 8-1/2"H x 48-1/2"D	TK10	DV9(5)
SA-20	Double Wide Deep	20"W x 12"H x 51-1/2"D	19-5/8"W x 8-1/2"H x 48-1/2"D	TK20	DV19(5)
SA-40	Full Wide Deep	40"W x 12"H x 51-1/2"D	9-5/8"W x 8-1/2"H x 48-1/2"D (2) 19-5/8"W x 8-1/2"H x 48-1/2"D	TK40	DV9(10) DV19(5)



SAJ-10



SAJ-20



SAJ-30



SAJ-40

### Stow-All Shallow Series Stow-All quality in a lower profile

Model	Description	Cabinet Size	Drawer Size	Traction Kit	Divider (Qty.)
SAJ-10	Single Wide Shallow	10"W x 8-1/2"H x 51-1/2"D	9-5/8"W x 5-1/4"H x 48-1/2"D	TK10	DVJ9(5)
SAJ-20	Double Wide Shallow	20"W x 8-1/2"H x 51-1/2"D	19-5/8"W x 5-1/4"H x 48-1/2"D	TK20	DVJ19(5)
SAJ-30	Triple Wide Shallow	30"W x 8-1/2"H x 51-1/2"D	9-5/8"W x 5-1/4"H x 48-1/2"D 19-5/8"W x 5-1/4"H x 48-1/2"D	TK30	DVJ9(5) DVJ19(5)
SAJ-40	Full Wide Shallow	40"W x 8-1/2"H x 51-1/2"D	9-5/8"W x 5-1/4"H x 48-1/2"D (2)	TK40	DVJ9(10)

### Aluminum Lock Box

- Stores valuable tools and paperwork.
- Gas shock safely opens and closes the large lid.
- The large lock will accommodate a padlock or hockey puck style lock (not included.)
- Designed to mount on the van floor facing out the side or rear doors.
- Aluminum construction with powder coat black paint.

**LKB1 Aluminum Lock Box**  
20" W, 14.5" H, 25" D



**NEW!**





# LADDER & CARGO RACKS

**THE STORAGE SPACE ON YOUR SPRINTER'S ROOF IS NO LONGER OUT OF REACH. ACCESS IT WITH ADRIAN'S SPRINTER LOADSRITE AND CARGO RACKS.**

## Sprinter LoadsRite

lowers the ladder down to you for easier loading and unloading.

- **Secure** – Ladder clamps hold ladder tight during transportation.
- **Ladder protection** – Fiberglass ladders are protected by a layer of plastic when loaded on the rack.
- **Safe** – Two hand operation required to release ladder down into load and unload position.
- **Durable** – 3rd cross support protects drive shaft, greatly reducing wear and tear.
- **Easy operation** – Rollers and dampers create a smooth transition to the stowed and down positions.
- **Back saver** – Designed to allow loading and unloading of ladders one end at a time.
- **Easy reach handle** – Release handle slides down lower than competing racks for easier reach.
- **Ladder capacity** – Accommodates 16'-32' extension ladders.



Catalog #	Description
SPRLR-S61	Sprinter LoadsRite, standard roof, single, street/curbside
SPRLR-H61	Sprinter LoadsRite, high roof, single, street/curbside
SPRLR-62	Sprinter LoadsRite Add On Kit, street/curbside
SPRLR-S63	Sprinter LoadsRite, standard roof, double
SPRLR-H63	Sprinter LoadsRite, high roof, double



**Stowed Position**



**Rotate Handle**



**Primary Drop**



**Secondary Drop**

## Sprinter VP Rack

- **Versatile** – Designed to carry multiple types of cargo on the roof.
- **Load assist** – Angled rear bar assists in loading and unloading of cargo.
- **Carrying capacity** – Perimeter rails maximize roof space cargo storage.
- **Durable** – Powder coated steel for strength and durability. Available in black or white finish.



## Sprinter 3 Bar Rack

- **Versatile** – Designed to carry multiple types of cargo on the roof.
- **Durable** – Powder coated steel for strength and durability. Available in black or white finish.

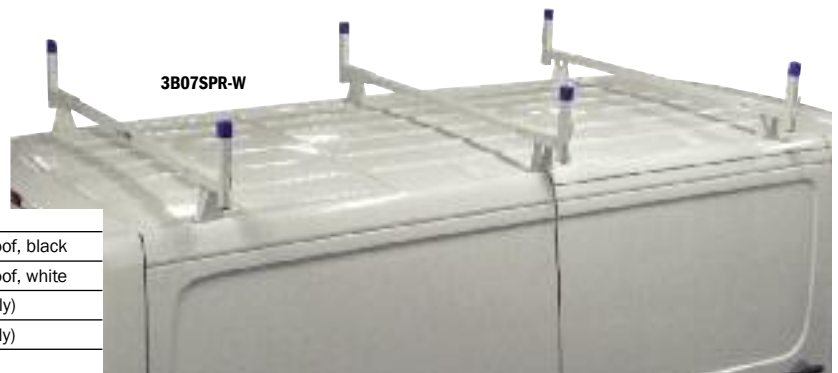

Catalog #	Description
VP107SPR-B	Perimeter Rack, 07-On Sprinter, standard & high roof, black
VP107SPR-W	Perimeter Rack, 07-On Sprinter, standard & high roof, white
VPE07SPR-B	Perimeter Rack Extension, black (170" Sprinter Only)
VPE07SPR-W	Perimeter Rack Extension, white (170" Sprinter Only)
3B07SPR-B	3Bar, 07-On Sprinter, standard & high roof, black
3B07SPR-W	3Bar, 07-On Sprinter, standard & high roof, white
1B07SPR-B	1Bar, 07-On Sprinter, standard & high roof, black
1B07SPR-W	1Bar, 07-On Sprinter, standard & high roof, white

# 144" WHEELBASE BASEPLUS PACKAGES



**BASEPLUS MAKES IT EASY TO GET TRADE SPECIFIC. FOR FLEXIBLE INTERIOR STORAGE-COUNT ON ADRIAN EXPERIENCE TO DELIVER.**

Start with the basics like shelving and a partition. Then add everything you need, where you need it. The Base Commercial Package gets you started with ample shelving and a partition, then upgrade to one of three trade specific packages that add accessories like door kits, hooks, tank racks, reel holders and drawers.

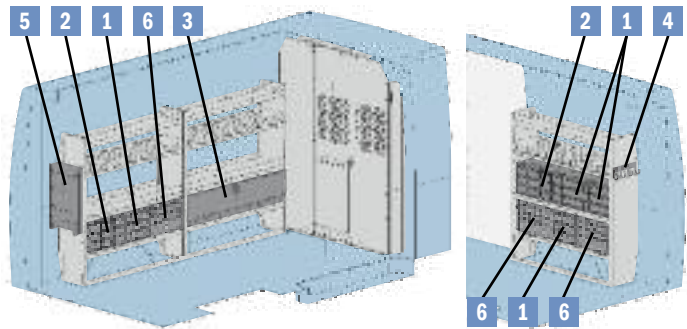
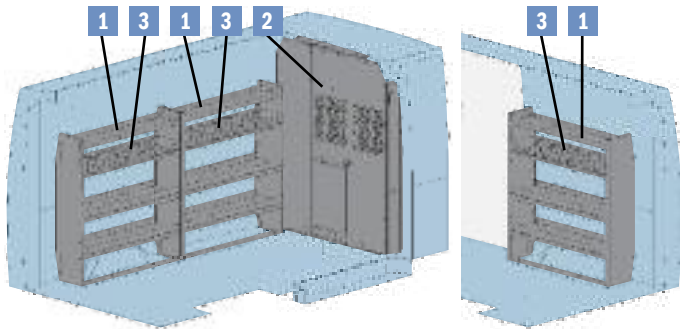

## 144" Sprinter Base Commercial Package

4009H High Roof Package  
4009S Standard Roof Package

Item	Model	Description	Qty.
1	HD52SPR	Heavy Duty Adjustable Closed Ended Shelving Unit 14x56x52	3
2	S1M2HC2	Partition/O7/Sprinter	1
3	DV14	14" Divider (included with shelf units)	15

## 144" Sprinter BasePlus Electrical Package

4010H High Roof Package  
4010S Standard Roof Package

Item	Model	Description	Qty.
<b>4009H Commercial Package PLUS</b>			
1	DC12	Drawer Component 12" Wide	4
2	DC6	Drawer Component 6" Wide	7
3	DK552SPR	Door Kit/Back Panel/52"	1
4	TA1	Four Hook Bar	1
5	WRH5	Wire Reel Holder 6" 5-Bar	1
6	919	3-Drawer Combo	3

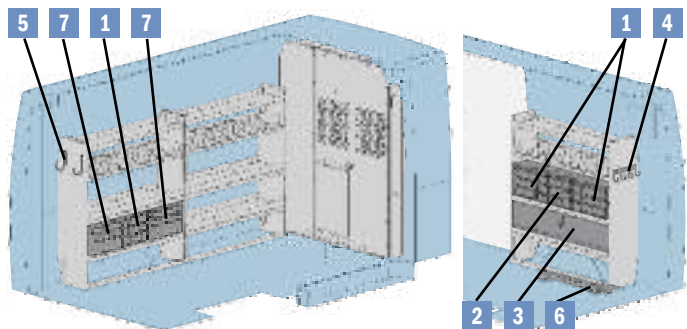
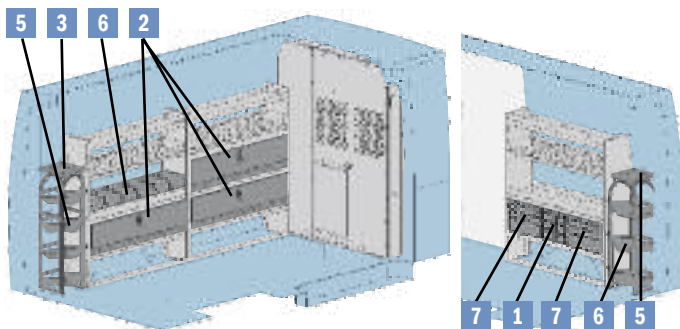

## 144" Sprinter BasePlus HVAC Package

4011H High Roof Package  
4011S Standard Roof Package

Item	Model	Description	Qty.
<b>4009H Commercial Package PLUS</b>			
1	DC6	Drawer Component 6" Wide	2
2	DK552SPR	Door Kit/Back Panel/52"	3
3	WTRTRAY	Shelf Assembly/Top/Tank Rack	2
4	WTR350	Welded Tank Rack, 3-50	1
5	WTR430	Welded Tank Rack, 4-30	1
6	28 LINBIN	Blue/10x8x7	6
7	919	3-Drawer Combo	2

## 144" Sprinter BasePlus Plumbing Package

4012H High Roof Package  
4012S Standard Roof Package

Item	Model	Description	Qty.
<b>4009H Commercial Package PLUS</b>			
1	DC12	Drawer Component 12" Wide	3
2	DC6	Drawer Component 6" Wide	4
3	DK552SPR	Door Kit/Back Panel/52"	1
4	TA1	Four Hook Bar	1
5	UH50	Utility Hook/5"	2
6	VMA36	Vise Mount Assy.	1
7	919	3-Drawer Combo	2



# 144" WHEELBASE TRADE PACKAGES

## DON'T LET ALL THAT SPACE INSIDE YOUR SPRINTER CARGO VAN INTIMIDATE YOU. ORGANIZE IT WITH ADRIAN STEEL!

If you just don't know where to start, turn to Adrian for ideas on how to best maximize that precious space inside your Sprinter Van. Trade packages are designed for several different vocations with trade specific equipment like tank racks and small parts storage. If you don't see exactly what you are looking for, that's ok! Trade packages are thought starters, designed to give you ideas to run with as you combine the Adrian shelving, cabinets, drawers and modules to fit your specific needs.

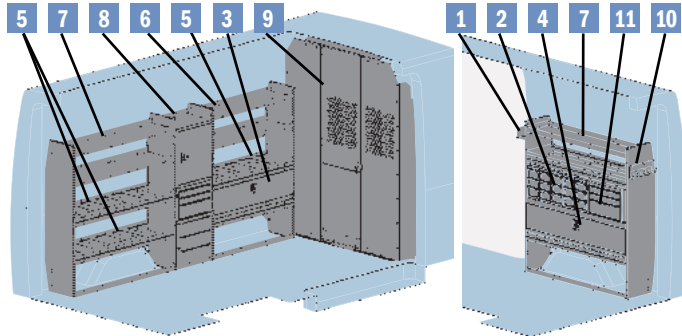

### 144" Sprinter General Service Package

4013H High Roof Package  
4013S Standard Roof Package

Item	Model	Description	Qty.
1	ACT3	Aerosol Can Tray 3-Hole	1
2	DC6	Drawer Component 6" Wide	5
3	DK542	Door Kit/Back Panel/42"	1
4	DK552	Door Kit/Back Panel/52"	1
5	DV14	Divider/4x14	12
6	HD-42SWP	HD Adj. Closed Ended Shelving 14x56x42	1
7	HD-52SWP	HD Adj. Closed Ended Shelving 14x56x52	2
8	MD603	Drawer/Cabinet/Module 12x54x18	1
9	S1M2HC2	Partition/07/Sprinter	1
10	TA1	Four Hook Bar	1
11	919	3-Drawer Combo	1

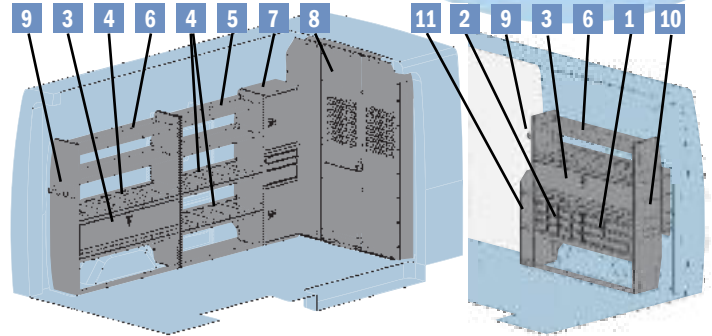

### 144" Sprinter Electrical Package

4014H High Roof Package  
4014S Standard Roof Package

Item	Model	Description	Qty.
1	DC12	Drawer Component 12" Wide	2
2	DC6	Drawer Component 6" Wide	4
3	DK552	Door Kit/Back Panel/52"	2
4	DV14	Divider/4x14	12
5	HD-42SWP	HD Adj. Closed Ended Shelving 14x56x42	1
6	HD-52SWP	HD Adj. Closed Ended Shelving 14x56x52	2
7	MD601	Drawer/Cabinet/Module 12x56x18	1
8	S1M2HC2	Partition/07/Sprinter	1
9	TA1	Four Hook Bar	2
10	WRH5	Wire Reel Holder 5-Bar	1
11	43	Three Shelf Catalog File	1

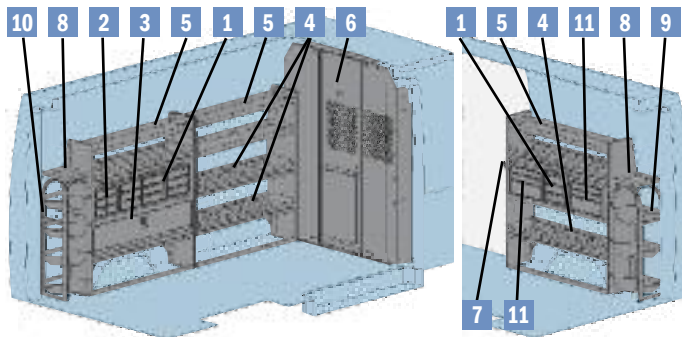

### 144" Sprinter HVAC Package

4015H High Roof Package  
4015S Standard Roof Package

Item	Model	Description	Qty.
1	DC12	Drawer Component 12" Wide	4
2	DC6	Drawer Component 6" Wide	2
3	DK552	Door Kit/Back Panel/52"	1
4	DV14	Divider/4x14	12
5	HD-52SWP	HD Adj. Closed Ended Shelving 14x56x52	3
6	S1M2HC2	Partition/07/Sprinter	1
7	TA1	Four Hook Bar	1
8	WTRTRAY	Shelf Assembly/Top/Tank Rack	2
9	WTR350	Welded Tank Rack/3-50	1
10	WTR430	Welded Tank Rack/4-30	1
11	919	3-Drawer Combo	2

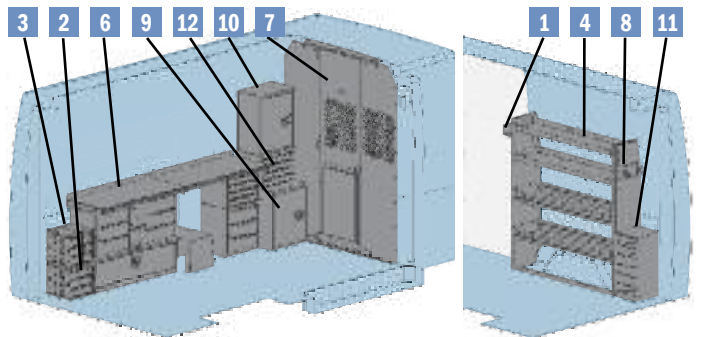

### 144" Sprinter Locksmith Package

4016H High Roof Package  
4016S Standard Roof Package

Item	Model	Description	Qty.
1	ACT3	Aerosol Can Tray 3-Hole	1
2	DC12	Drawer Component 12" Wide	1
3	DC6	Drawer Component 6" Wide	2
4	HD-52SWP	HD Adj. Closed Ended Shelving 14x56x52	1
5	KMB36	Key Machine Base 36" (not shown)	1
6	MD610	Workbench Module 18x32x84	1
7	S1M2HC2	Partition/07/Sprinter	1
8	TA1	Four Hook Bar	1
9	1	Cabinet 18x22x18	1
10	12	Cabinet 12x22x18	1
11	17A	Catalog File 6 Shelf	1
12	9	4-Drawer Shallow	1
13	12A	End Panel #12 (not shown)	1

Note: Illustrations and descriptions are for 2007 and newer Sprinter vehicles. Call Adrian Steel for package information for 2006 and older Sprinter vehicles.

# 170" WHEELBASE BASEPLUS PACKAGES



**BASEPLUS MAKES IT EASY TO GET TRADE SPECIFIC. FOR FLEXIBLE INTERIOR STORAGE-COUNT ON ADRIAN EXPERIENCE TO DELIVER.**

Start with the basics like shelving and a partition. Then add everything you need, where you need it.

The Base Commercial Package gets you started with ample shelving and a partition, then upgrade to one of three trade specific packages that add accessories like door kits, hooks, tank racks, reel holders and drawers.

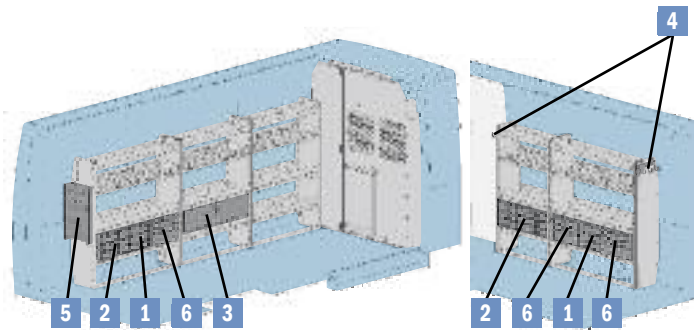
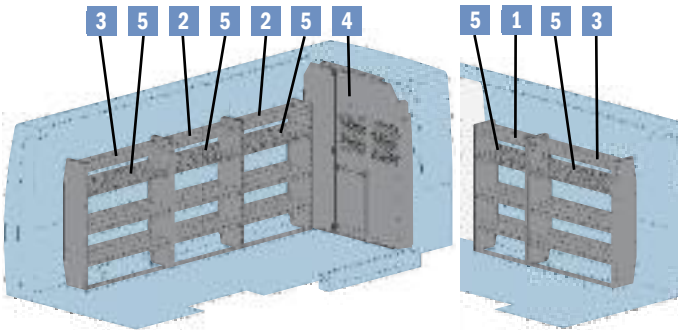

## 170" Sprinter Base Commercial Package

4005H High Roof Package

Item	Model	Description	Qty.
1	HD32SPR	Heavy Duty Adjustable Closed Ended Shelving Unit 14x56x32	1
2	HD42SPR	Heavy Duty Adjustable Closed Ended Shelving Unit 14x56x42	2
3	HD52SPR	Heavy Duty Adjustable Closed Ended Shelving Unit 14x56x52	2
4	S1M2HC2	Partition/O7/Sprinter	1
5	DV14	14" Divider (included with shelf units)	21

## 170" Sprinter BasePlus Electrical Package

4006H High Roof Package

Item	Model	Description	Qty.
<b>4005H Commercial Package PLUS</b>			
1	DC12	Drawer Component 12" Wide	2
2	DC6	Drawer Component 6" Wide	8
3	DK542SPR	Door Kit/Back Panel/42"	1
4	TA1	Four Hook Bar	2
5	WRH5	Wire Reel Holder 6" 5-Bar	1
6	919	3-Drawer Combo	3

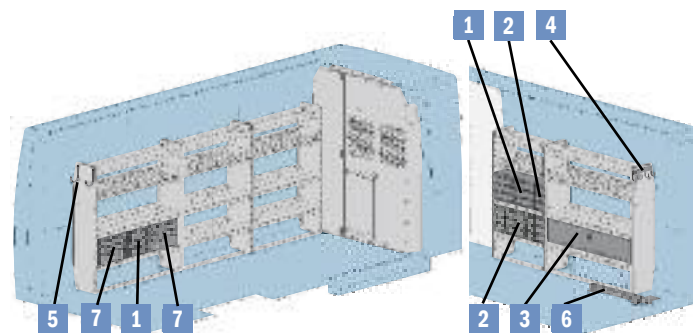
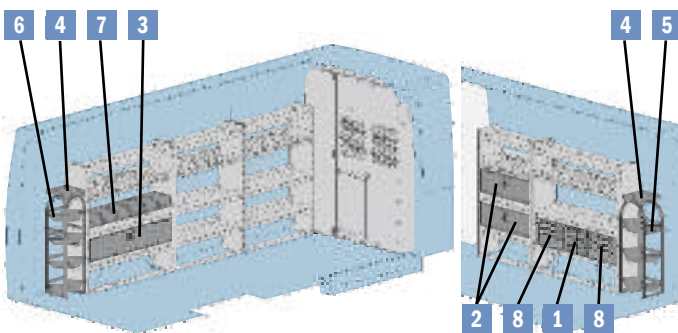

## 170" Sprinter BasePlus HVAC Package

4007H High Roof Package

Item	Model	Description	Qty.
<b>4005H Commercial Package PLUS</b>			
1	DC6	Drawer Component 6" Wide	2
2	DK532SPR	Door Kit/Back Panel/32"	2
3	DK552SPR	Door Kit/Back Panel/52"	1
4	WTRTRAY	Shelf Assembly,Top,Tank Rack	2
5	WTR350	Welded Tank Rack, 3-50	1
6	WTR430	Welded Tank Rack, 4-30	1
7	28 LINBIN	Blue 10x8x7	6
8	919	3-Drawer Combo	2

## 170" Sprinter BasePlus Plumbing Package

4008H High Roof Package

Item	Model	Description	Qty.
<b>4005H Commercial Package PLUS</b>			
1	DC12	Drawer Component 12" Wide	3
2	DC6	Drawer Component 6" Wide	6
3	DK552SPR	Door Kit/Back Panel/52"	1
4	TA1	Four Hook Bar	1
5	UH50	Utility Hook, 5"	2
6	VMA36	Vise Mount Assembly	1
7	919	3-Drawer Combo	2

# 170" WHEELBASE TRADE PACKAGES

## DON'T LET ALL THAT SPACE INSIDE YOUR SPRINTER CARGO VAN INTIMIDATE YOU. ORGANIZE IT WITH ADRIAN STEEL!

If you just don't know where to start, turn to Adrian for ideas on how to best maximize that precious space inside your Sprinter Van. Trade packages are designed for several different vocations with trade specific equipment like tank racks and small parts storage. If you don't see exactly what you are looking for, that's ok! Trade packages are thought starters, designed to give you ideas to run with as you combine the Adrian shelving, cabinets, drawers and modules to fit your specific needs.

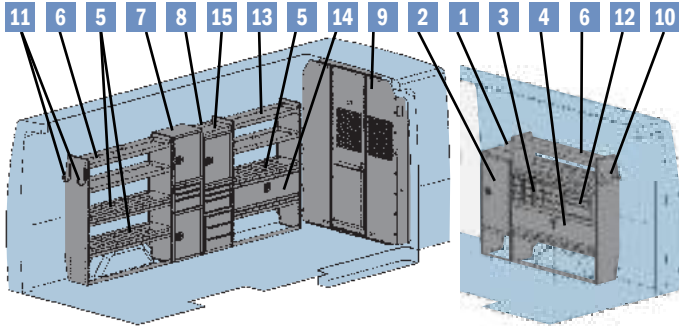

### 170" Sprinter General Service Contractor Package

#### 4001H High Roof Package

Item	Model	Description	Qty.
1	ACT3	Aerosol Can Tray/3-Hole	1
2	CL1446D	Cable Locker Mid Door	1
3	DC6	Drawer Component 6" Wide	5
4	DK552	Door Kit 52"	1
5	DV14	Divider 4x14	12
6	HD-52SWP	HD Adj. Closed Ended Shelving 14x56x52	2
7	MD601	Drawer/Cabinet Module 12x56x18	1
8	MD603	Drawer/Cabinet Module 12x54x18	1
9	S1M2HC2	Partition/07/Sprinter	1
10	TA1	Four Hook Bar	1
11	UH50	5" Hook Bar	2
12	919	3-Drawer Combo	1
13	HD-42SWP	HD Adj. Closed Ended Shelving 14x56x42	1
14	DK542	Door Kit 42"	1
15	4B	Parts Tray	1

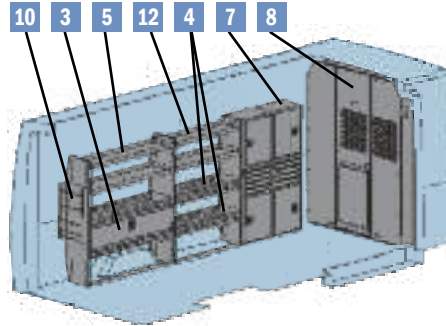

### 170" Sprinter Electrical Service Package

#### 4002H High Roof Package

Item	Model	Description	Qty.
1	DC12	Drawer Component 12" Wide	2
2	DC6	Drawer Component 6" Wide	4
3	DK552	Door Kit 52"	2
4	DV14	Divider 4x14	16
5	HD-52SWP	HD Adj. Closed Ended Shelving 14x56x52	2
6	MD601	Drawer/Cabinet Module 12x56x18	1
7	MD604	Drawer/Cabinet Module 12x56x36	1
8	S1M2HC2	Partition/07/Sprinter	1
9	TA1	Four Hook Bar	1
10	WRH5	Wire Reel Holder 5-Bar	1
11	43	Catalog File 34"	1
12	HD-42SWP	HD Adj. Closed Ended Shelving 14x56x42	1

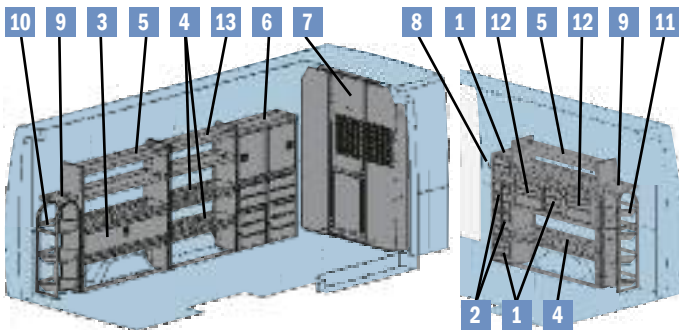

### 170" Sprinter HVAC Package

#### 4003H High Roof Package

Item	Model	Description	Qty.
1	DC12	Drawer Component 12" Wide	3
2	DC6	Drawer Component 6" Wide	4
3	DK552	Door Kit 52"	1
4	DV14	Divider 4x14	12
5	HD-52SWP	HD Adj. Closed Ended Shelving 14x56x52	2
6	MD605	Drawer/Cabinet Module 12x54x36	1
7	S1M2HC2	Partition/07/Sprinter	1
8	TA1	Four Hook Bar	1
9	WTRTRAY	Shelf Assy,Top,Tank Rack	2
10	WTR350	Welded Tank Rack, 3-50	1
11	WTR430	Welded Tank Rack, 4-30	1
12	919	3-Drawer Combo	2
13	HD-42SWP	HD Adj. Closed Ended Shelving 14x56x42	1

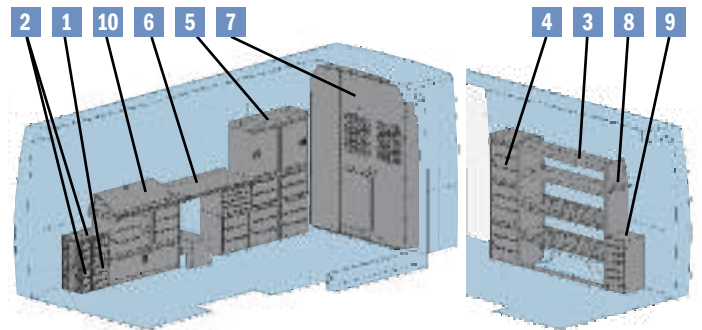

### 170" Sprinter Locksmith Package

#### 4004H High Roof Package

Item	Model	Description	Qty.
1	DC12	Drawer Component 12" Wide	1
2	DC6	Drawer Component 6" Wide	4
3	HD-52SWP	HD Adj. Closed Ended Shelving 14x56x52	1
4	MD602	Drawer/Cabinet Module 12x56x18	1
5	MD605	Drawer/Cabinet Module 12x54x36	1
6	MD610	Workbench Module 18x32x84	1
7	S1M2HC2	Partition/07/Sprinter	1
8	TA1	Four Hook Bar	1
9	17A	Catalog File 6 Shelf	1
10	KMB36	Key Machine Base 36"	1

Note: Illustrations and descriptions are for 2007 and newer Sprinter vehicles. Call Adrian Steel for package information for 2006 and older vehicles. 170" interior installed in a Mega High roof Sprinter will require OEM partition.



# ADRIAN STEEL COMPANY

## QUALITY

- Adrian Steel is proud to be the first and only van equipment manufacturer to obtain TS16949 certification.
- Our products are durable and reliable. Warranty claims are less than 1% of sales.
- Our warranty covers our products for three years or 36,000 miles.

## INNOVATIVE PRODUCTS WITH FEATURES THAT MATTER

- Drawers that stay closed while in transit.
- Heavy duty, adjustable shelving.
- LoadsRite ladder racks that load and unload the safe and right way.
- Trade specific accessories including tank racks, cable reel holders and vice mounts.
- Plug and Play accessories.
- Anti-slam drawer latches, and much more!



## COMMITMENT

- At Adrian Steel, we are committed to you beyond the upfit!
  - A dedicated Customer Care Team at corporate headquarters.
  - A network of highly qualified distributors to support you locally.
  - Our commitment to provide the best cargo management solutions in North America.

## EXPERIENCE

- Over One Million vans upfitted, and counting! It's a fact that an organized vehicle increases work flow efficiencies and reduces inventory damages.
- Recognized as a National Truck Equipment Association MVP.

## SERVICE

- Adrian Steel Products can be purchased throughout North America at authorized Adrian Steel distributors.
- Adrian Steel Customer Service Representatives are available M-F, 8am - 5pm EST at **1-800-677-2726**.
- E-mail us at [info@adriansteel.com](mailto:info@adriansteel.com) with questions, comments and feedback.
- Visit [AdrianSteel.com](http://AdrianSteel.com) for the most up-to-date product information, distributor locator, product catalogs, videos and more.

**FIND THE SOLUTIONS YOU NEED AT YOUR ADRIAN STEEL DISTRIBUTOR,  
IN OUR CATALOGS AND ON-LINE AT [ADRIANSTEEL.COM](http://ADRIANSTEEL.COM).**



**CARGO VAN**



**PICKUP TRUCK**



**SPRINTER VAN**



**WALK-IN VAN**



**CARGO TRAILER**

Distributed by



906 James Street, Adrian, Michigan 49221-3996  
517-265-6194 Fax: 517-265-5834  
Toll Free 800-677-2726  
[adriansteel.com](http://adriansteel.com) [info@adriansteel.com](mailto:info@adriansteel.com)