



PORSCHE



The new 911
Porsche identity



Strength	6
Exterior design	12
Interior design	16
Engineering	18
The new 911 Carrera	20
The new 911 Carrera S	22
Temperament	24
Engines	26
Transmission	36
Chassis and body	40
Composure	56
Safety	58
Comfort	66
Responsibility	88
Motorsport	90
Environment	96
Personality	100
Personalisation	102
Panorama	116
911 identity	118
Technical data	120
Index	122



grounded
enthusiastic
Strength
courageous liberated
direct determined
mature spirited

**Many legends look to the past.
This one looks to the future.**

The new 911.

At the beginning, we took time to reflect on where we came from and, above all, where we want to be.

One thing was clear. To be able to build the new 911, we would need to find the right answers. What is it that defines us? The engineering credentials as suggested by the 'Dr. Ing.' in our company name, certainly. More than 28,000 racing victories, definitely. Not just feats of heroism any longer, but responsibility for the future of the sportscar and for the environment. Then there is our reputation as an iconic sportscar manufacturer. However, this reputation means nothing unless we continue to breathe new life into old ideas.

For us, heritage and future are inseparably linked. Of course, we could simply have made a capable sportscar, but this wouldn't have been a Porsche, and certainly not a 911.

Our identity is the 911. This is especially true, even in the 21st century. Instantly recognisable and originally engineered for the racetrack, it continues to stir the emotions today, just as it did in 1963.

Yet, is that enough to move forward? Above all, is it enough for you? Don't we need to break the stranglehold of tradition once in a while before it one day stifles innovation altogether? We believe that

the answer is 'yes', which is why no fewer than 90% of the components of the 911 are either new or have been fundamentally revised. This is our approach to the preservation of tradition. It is precisely how we respond to the passion for the sportscar and do justice to the 911 legend, and always with tomorrow in mind.

We have achieved this with a brand new design and a longer wheelbase, with refined engines that consume less fuel but deliver more power, with efficiency-enhancing technologies such as auto start/stop, thermal management and electrical system recuperation, with an intelligent lightweight body that uses a

composite blend of aluminium and steel, with a suspension derived from motorsport, and with a progressive interior designed for sporty comfort.

All of that is what defines us. In short, it is the way in which we combine tradition and innovation, performance and everyday practicality, form and function. For us, these are not contradictions, but our motivation. We are referring to Intelligent Performance.

Our identity can be accurately described by many words, and by one number.

The new 911. Porsche identity.



Identity is a combination of disposition, personality and heritage. In our attempt to understand it, we tend to compare differences.

This is equally true in the case of the 911 model range. With defining attributes such as performance, efficiency, style and comfort, they reveal a character of their own and fulfil your individual expectations – not just of any sports car, but of a 911.

The new 911 Carrera.
The new 911 Carrera S.





Can you imagine a face without an expression?

Exterior design.

Every child recognises a 911, but can its identity be described in words? It can, by looking more closely at the use of form, proportions and contours. The roof line tapers down into the rear. The wings are higher than the front lid and, at the rear, they add muscle. They give the 911 its distinctive expression and leave you in no doubt as to its temperament.

The overall appearance is low, wide and sleek. Typically 911.

So, is everything just the same as it has been since 1963? Yes, and no. After all, only those who change will remain true to themselves – and we've changed.

Our designers and engineers speak guardedly about the 911 evolution. Meanwhile, they continually manage to take great strides forward with innovations motivated by the principle that these should be functional and perfectly compatible. The result is a harmonious overall concept that makes the new 911 a sportscar fit for the 21st century.

To show you what we mean, we should start by looking at the car's exterior. The wheelbase of the new 911 is 100 mm longer for improved driving stability and cornering dynamics. Overhang is now shorter at the front and rear, making the new 911 look even more compact.

The sporty overall impression is emphasised by the lower roof line and a wider track at the front – 46 mm on the 911 Carrera and 52 mm on the 911 Carrera S. For improved aerodynamics, the exterior mirrors are now mounted directly on the doors. Increased agility is just one of the results of all these refinements.

The silhouette is therefore typically 911 and typical in terms of its development, which will now be described in more detail.

The modified vehicle architecture, with a wider track at the front axle and the lower roof line, gives the front of the new 911 a dynamic appearance that is sporty and elegant. Fitted as standard, the new Bi-Xenon headlights still have the familiar oval-shaped surrounds for classic appeal and reveal their technically impressive inner workings. The Porsche Dynamic

Light System (PDLS) with dynamic cornering lights and speed-sensitive headlight control logic is available as an option.

The direction indicators, daytime running lights and position lights are all LEDs and are integrated into the separate front light units. Their slimline design contrasts with

that of the rounded headlights. Together with the two integral air intakes, they make the front of the new 911 unmistakable.

At the rear, everything feels sharper: the styling, the appearance and the effect. This is due not least to the distinctive profile edge and new LED taillights, their stretched design accentuating

the horizontal contouring of the rear. The characteristic reflector units have been positioned lower down but are still recognisable, particularly at night.

The stainless-steel tailpipes have been restyled for both models. On the 911 Carrera S, twin tailpipes are fitted on both sides. One new feature is the wider,

extendable rear spoiler, which reduces lift in all driving situations and increases driving stability.

The 911 Carrera and the 911 Carrera S are equipped as standard with 19-inch and 20-inch wheels respectively. One inch larger than those of the previous model, they enhance the sporty presence of the

new 911 and their increased rolling circumference improves both comfort and performance.

In summary, form always follows function. As a design principle, it couldn't be more simple, but it's what makes the 911 a 911.

It's also how we have managed to achieve a very low drag coefficient of just 0.29.

Even the logo on the rear has an important function to perform. It is, after all, the hallmark of the Porsche identity.



**Sporty ergonomics for ordinary driving.
Extraordinary comfort for sporty driving.**

Interior design.

At Porsche, we don't build everyday sportscars, we build sportscars for everyday use. How? By understanding that great agility and maximum comfort are not mutually exclusive but are, in fact, aspects of a harmonious overall concept.

This is especially true of the interior of the new 911. Sportiness, functionality and high-quality materials combine to form a cohesive whole that is conducive to dynamic driving, even during everyday use.

What this means becomes clear the moment you get in. The extended wheelbase now offers 25 mm more leg room in the front than in previous 911 models.

Sportiness in harmony with comfort is the theme which is reflected in the clever ergonomics that characterise the entire interior design. The materials used, the layout of the controls and their operating logic belong to a new generation of sportscar. Another new design for the new 911 is the elevated centre console. Its intelligent operating concept follows a clear principle of direct simplicity.

A classic 911 feature is the arrangement of the five circular instruments with the rev counter in the middle. A new addition is the instrument cluster featuring a high-resolution 4.6-inch full VGA TFT colour display for viewing on-board computer, audio system or navigation information.

Fitted as standard, the Sports seats combine even greater comfort with racing-style support and now feature 4-way electric adjustment. The new automatic climate control with zonal temperature controls for driver and front passenger also comes as standard. Also new is the optional light design package for the footwells, storage compartments, rear compartment and overhead console. As ever, we offer an extensive selection of interior colours and materials, such as carbon, leather, wood or aluminium.

Acoustics are an integral part of the concept, particularly the engine sound. Available as an option is the Burmester®

High-End Surround Sound System. Optimised for the new 911 Carrera models, it features 12 loudspeakers and a total output of 821 watts for a perfect spatial sound.

The new 911 proves that apparent opposites, such as style and engineering or comfort and performance, can go hand in hand. For us, there is no contradiction and certainly no need for compromise. After all, a strong personality does not deny the existence of opposites, it unites them.





**Let's forget the future for a moment.
As we discover it in the present.**

Engineering.

What use is the engineering of tomorrow when it can be found on the road today? None. So let's turn to the here and now.

The engines, as you would expect, are characterised by six horizontally opposed cylinders. The 3.4-litre engine in the 911 Carrera produces 257 kW (350 hp); in the 911 Carrera S, the 3.8-litre engine develops 294 kW (400 hp). Both models are equipped with direct fuel injection (DFI) and VarioCam Plus for increased power and reduced fuel consumption. This power is transmitted to the wheels by the new and efficient 7-speed manual gearbox or, optionally, by Porsche Doppelkupplung (PDK), which

offers gear changes with no interruption in the flow of power.

Both engines deliver improved sporty performance compared with the engine in the previous model and yet fuel consumption has been reduced by up to 16%. How was this achieved? One explanation is the reduced capacity of 3.4 litres in the 911 Carrera. Another is the total redevelopment of the engine peripherals with groundbreaking efficiency-improving technologies.

As standard, these include the auto start/stop function, electrical system recuperation and intelligent thermal

management as well as the new, energy-saving electromechanical steering system and, in the case of PDK, the introduction of the coasting function (for more information, please refer to page 39 onwards).

The chassis is also packed with forward-looking technology. Fitted as standard in the 911 Carrera S, Porsche Torque Vectoring (PTV) increases dynamic performance. Available as an option for the S model, Porsche Dynamic Chassis Control (PDCC) improves dynamic performance further still. Dynamic engine mounts, included as part of the optional Sport Chrono Package, are now available for the 911 Carrera models for the first time.

These provide perceptibly more stable handling under load change conditions and in fast corners.

The new 911 has a lightweight composite construction in aluminium and steel. Used extensively and in just the right places, lightweight aluminium improves fuel economy and dynamic performance and helps to achieve a low weight to power ratio of 4.7 kg/kW (3.5 kg/hp) for the 911 Carrera S.

The future of the sports car begins now.

911 Carrera models: fuel consumption (in l/100 km) urban 13.8–11.2 · extra urban 7.1–6.5 · combined 9.5–8.2; CO₂ emissions 224–194 g/km

Meetings, conferences, business lunches. How about some leisure in between?

The new 911 Carrera.

In the 21st century, we find ourselves caught between all kinds of opposites on a daily basis: between the demands of our work life and our private life, between the real world and virtual reality. How can they all be reconciled? With a strong identity and a sportscar that has incorporated many contradictory notions since 1963.

Sportiness and everyday practicality are a prime example. The new 911 Carrera is equipped as standard with direct fuel injection (DFI) and VarioCam Plus for high power, high torque, efficient combustion and, as a result, comparatively low fuel consumption.

Tradition and innovation blend seamlessly together in the new rear-mounted 3.4-litre flat-six engine thanks to its downsized capacity. Despite the reduced displacement, the engine is capable of delivering even more power to the road than its 3.6-litre predecessor.

The figures speak for themselves. The maximum power of 257 kW (350 hp) is available at 7,400 rpm and the maximum torque of 390 Nm is generated at 5,600 rpm. Yet, in conjunction with Porsche Doppelkupplung (PDK), fuel consumption and CO₂ emissions have been reduced by 16%. Even more impressively, the car accelerates from 0 to 100 km/h

in 4.8 seconds and reaches a top speed of 289 km/h.

The new 911 Carrera generates powerful forces, which are transmitted precisely and directly to the wheels by the new 7-speed manual gearbox. As with the optional PDK, gears 1 to 6 have a sports ratio, while 7th gear has a long ratio for reduced fuel consumption. The SPORT button, which is fitted as standard, makes it possible to select an even more responsive engine and transmission setup.

In terms of form and function, the new single tailpipes are especially imposing and emit a sound which is typically

Porsche. The 19-inch Carrera wheels are fitted as standard and improve driving stability and performance.

Sportscar technology as standard, in the form of black four-piston monobloc aluminium fixed calipers, Porsche Stability Management (PSM) and Bi-Xenon headlights, shows that sportiness and safety are not mutually exclusive.

Sport, moderation, everyday practicality and style. Four key themes, one unifying concept: the 911 Carrera.





Its identity emerged on the racetrack.

Its home is on the road.

The new 911 Carrera S.

Nothing defines us more than our heritage. It says a lot about who we are. This is particularly true of the new 911 Carrera S, which has all the characteristics you would expect of a sports car whose origin is in motorsport.

An elementary component of its DNA, therefore, is power in the form of a 3.8-litre engine with direct fuel injection (DFI) and VarioCam Plus. It delivers 294 kW (400 hp) at 7,400 rpm, and the maximum torque of 440 Nm is achieved at 5,600 rpm. In conjunction with the manual gearbox, the sprint from 0 to 100 km/h is completed in just 4.5 seconds. Top speed isn't reached until 304 km/h.

On figures alone, the new 911 Carrera S excels, particularly in terms of efficiency. Fuel consumption and CO₂ emissions have been reduced by 14% compared with the previous model. This has been possible thanks to the auto start/stop function, which is available as standard, and the coasting function in conjunction with the optional Porsche Doppelkupplung (PDK).

It's not difficult to tell where the 911 Carrera S comes from. You can hear it in the resonant engine sound and you can see it in the twin tailpipes in brushed stainless steel and 20-inch Carrera S wheels.

You can also feel it, thanks to Porsche Active Suspension Management (PASM), which is fitted as standard, or the optional PASM sports suspension with sporty aerodynamics and the ride height lowered by 20 mm. Or the optional Sport Chrono Package and dynamic engine mounts. Available as standard, Porsche Torque Vectoring (PTV), or Porsche Torque Vectoring Plus (PTV Plus) in conjunction with the optional PDK, increase traction. Porsche Dynamic Chassis Control (PDCC), the active roll stabilisation system, is available as an option and improves agility, comfort and safety.

On the subject of safety, the brakes at the front of the new 911 Carrera S come equipped for the first time with monobloc fixed calipers with six instead of four pistons for improved braking performance and a shorter braking distance. Bi-Xenon headlights are standard and the Porsche Dynamic Light System (PDLS) is available as an option.

There is no doubt. The new 911 Carrera S knows its roots, and embraces them with efficiency, power and sporty performance.

911 Carrera S: fuel consumption (in l/100 km) urban 13.8–12.2 · extra urban 7.1–6.7 · combined 9.5–8.7; CO₂ emissions 224–205 g/km

superior true
relaxed **assertive**
wild **Temperament**
efficient down-to-earth
spontaneous



To give more and take less. That's Porsche engineering.

Engines.

You could ask whether the sportscar is still relevant. It would be a good question, but you might as well ask the same of dreams.

The answer to both questions lies in the future or, to be more precise, in the future of the sportscar. In the new 911, the future has already begun. The highly efficient, state-of-the-art engines make a considerable contribution to reducing fuel consumption, but their sound is still unmistakably Porsche.

The new 911 engines are also unmistakably sporty thanks to the new SPORT button fitted as standard. At the push of a button, the engine becomes tuned for a sharper response and engine dynamics that are even more direct.

The 3.4-litre engine of the new 911 Carrera demonstrates, therefore, that performance and efficiency need not be mutually exclusive. Rather, the downsized engine capacity and increased maximum torque are the intelligent basis by which power output can be increased in an environmentally acceptable and sustainable way. Fuel consumption

and CO₂ emissions have been reduced by up to 16% compared with the previous model.

In their search for improved efficiency, our engineers analysed an extensive series of engine components. Answers were found, including rapid heating of the engine and gearbox by the new thermal management after an engine start, optimised air induction and the extremely effective direct fuel injection (DFI).

The same principle applies to the 3.8-litre engine in the 911 Carrera S. There has

been no change in displacement since the previous model, but power output has been increased while fuel consumption has been reduced by up to 14%.

Weight is critical to efficiency. This is why the engines have a light-alloy construction, which makes them lightweight and structurally rigid for improved fuel economy and a long life.

The engine is the intelligent core of our identity. What else could the 'Dr. Ing.' in our company name possibly stand for?



The new 3.4-litre engine.

The 911 Carrera is equipped with a 3.4-litre boxer engine with direct fuel injection (DFI) and VarioCam Plus. It develops 257 kW (350 hp) at 7,400 rpm and the maximum torque is 390 Nm at 5,600 rpm.

For the 911 Carrera with 7-speed manual gearbox, this means acceleration from 0 to 100 km/h in 4.8 seconds and a top speed of 289 km/h. With the optional Porsche Doppelkupplung (PDK), it means 0 to 100 km/h in just 4.6 seconds and a top speed of 287 km/h.

The new 3.8-litre engine.

The 911 Carrera S is powered by a 3.8-litre boxer engine with direct fuel injection (DFI) and VarioCam Plus. It produces 294 kW (400 hp) at 7,400 rpm and the maximum torque of 440 Nm is achieved at 5,600 rpm.

As a result, the new 911 Carrera S with 7-speed manual gearbox completes the sprint from 0 to 100 km/h in 4.5 seconds and reaches a top speed of 304 km/h. With the optional Porsche Doppelkupplung (PDK), the figures are 0 to 100 km/h in 4.3 seconds and a top speed of 302 km/h.

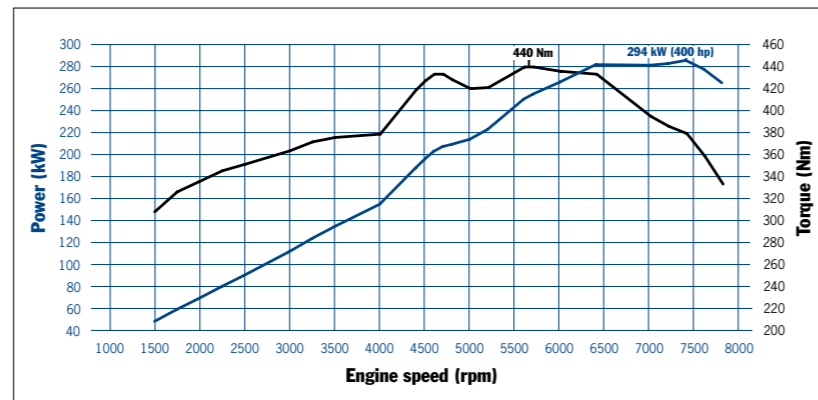
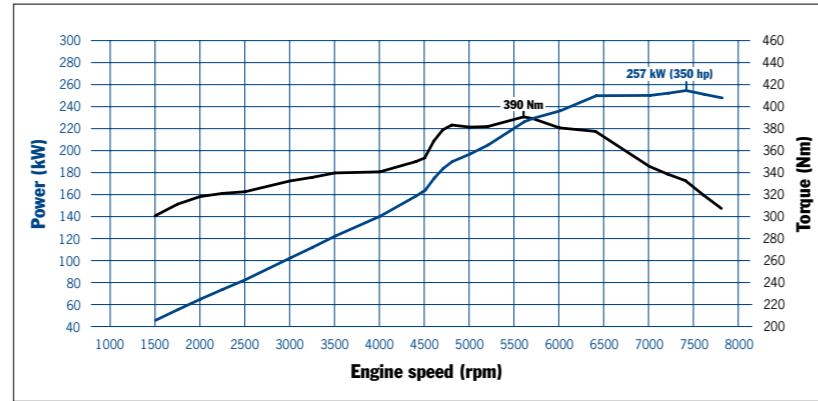

Engine cross section: 3.8-litre boxer engine

1. High-pressure pump
2. High-pressure injector
3. Ignition rod module
4. Camshaft controller
5. Valve lift adjustment switch valve
6. Switch tappet with integrated valve clearance compensation
7. Intake camshaft
8. Intake valves
9. Valve spring
10. Combustion chamber with Alusil cylinder liner surface
11. Forged aluminium piston
12. Forged connecting rod
13. Crankshaft
14. Water pump
15. Air-conditioning compressor
16. Power steering pump (in conjunction with PDCC)
17. Vibration damper
18. Alternator pulley with freewheel
19. Hydraulic belt tensioner
20. Resonance valve
21. Resonance distributor
22. Resonance valve actuator
23. Intake manifold with integrated sound chamber
24. Electronically controlled throttle valve
25. Oil filter
26. Electronic map-controlled thermostat
27. Vacuum pump
28. Coolant jacket
29. Crankcase breather
30. Timing chain
31. Starter

911 Carrera models: fuel consumption (in l/100 km) urban 13.8–11.2 · extra urban 7.1–6.5 · combined 9.5–8.2; CO₂ emissions 224–194 g/km

Not as thirsty as you might think.

Efficiency-enhancing measures.

A widely held belief about motorsport is that power is the only thing that matters. From experience, we know better. Extra horsepower alone has never been enough to win a single race. Much more important to us are ideas – ideas that inspire more intelligent vehicle concepts and more efficient drive systems. The same applies on the road. It's about getting the most out of what you've got.



Auto start/stop function.

The auto start/stop function is standard in the new 911 models.

In cars with the manual gearbox, the engine switches off automatically when, for example, you stop at traffic lights,

select neutral and release the clutch pedal. In cars with Porsche Doppelkupplung (PDK), the engine switches off whenever you stop and leave your foot on the brake pedal.

All audio and communication systems remain switched on and the climate control continues to maintain your selected temperature. The only differences you will notice are the silence at the rear and the fuel saving. As soon as you operate the clutch or release the brake, the engine will restart swiftly and smoothly.

The auto start/stop function may remain inactive under particular circumstances, extreme outside temperatures, when the SPORT button is selected or if battery charge is low. It is also possible to deactivate the function manually using a separate button on the centre console.

Thermal management.

The new thermal management system regulates the temperature in the engine and gearbox through the intelligent manipulation of heat flow.

In this way, the engine and gearbox reach their optimum operating temperature sooner. As a result, fuel consumption is reduced through increased combustion efficiency and lubrication performance.

Electrical system recuperation.

The new 911 models are also equipped as standard with fuel-saving electrical system recuperation technology. The vehicle battery is recharged by the alternator, predominantly under braking. Under acceleration, on the other hand, the power draw of the alternator is limited to increase the engine output available for driving. The electrical systems are supplied by the electrical energy stored during the recharging process.

What lies between your home and Le Mans? Advanced engineering as standard.

Direct fuel injection (DFI).

DFI delivers fuel directly into the combustion chamber with millisecond precision. The spray and cone angles of the new multi-hole injectors have been optimised for torque, power output, fuel consumption, emissions and efficient combustion.

With direct injection, the engine management system regulates injection timing individually for each cylinder as well as the injection rate for each cylinder bank. This optimises the combustion process and fuel economy.

For faster heating of the catalytic converters after a cold start and optimum torque in the upper load range, up to three injection pulses take place per combustion cycle.

DFI improves the internal cooling of the combustion chamber by having the mixture prepared directly in the cylinder. This allows for a higher compression ratio, which helps to deliver more output at the same time as enhanced engine efficiency. Injection is regulated by the electronic engine management system

and emissions are monitored by the Lambda sensors, thus helping to protect the environment.

VarioCam Plus System.

VarioCam Plus is a two-in-one engine concept for adjusting the intake camshafts and switching the lift of the intake valves.

The system first differentiates between driver inputs that typify normal, everyday driving and those inputs that demand maximum performance. The electronic engine management system then seamlessly adapts valve operation to the prevailing conditions. This results in instant acceleration, extremely smooth running and an extraordinary level of tractive power, but with a comparatively low level of fuel consumption.



Integrated dry-sump lubrication.

Integrated dry-sump lubrication ensures a reliable supply of oil even when a sporty driving style is adopted. It also has additional cooling functions.

The oil tank is located in the engine, thereby eliminating the need for an external oil tank, which saves both space and weight. To reduce power loss and increase efficiency, an electronically controlled oil pump supplies the lubricating points inside the engine as and when required. This results in optimum supply of oil, low fuel consumption and, therefore, lower exhaust emissions.

Air intake system.

The resonance intake system increases the intake volume by exploiting the fact that air oscillates as it passes through the intake manifold. The system can adjust to engine speed. Benefits of this include higher torque at low engine speeds and a flatter torque curve. The 911 Carrera S operates a two-stage system.

The entire intake system is made from lightweight plastic. In the new 911 Carrera, the resonator volume of the air filter housing varies with engine speed to bring added character to the engine sound, which becomes much more powerful at higher rpm.

Exhaust system.

The exhaust system of the new 911 models has been completely redesigned, acoustics included.

The stainless-steel exhaust system comprises two distinctive and independent exhaust tracts. The catalytic converters heat up rapidly for effective emissions reduction.

A selectable twin-tube sports exhaust system featuring distinctive polished stainless-steel tailpipes is available as an option. Activated by a button, it produces an even more intensive sportscar sound.



Single-tube tailpipe on the 911 Carrera



Twin-tube tailpipe on the 911 Carrera S



Twin tailpipe of the sports exhaust system

Engine management system.

The EMS SDI 9.1 engine management system ensures optimum engine performance at all times.

It controls, for example, the position of the electronic throttle valve (ETC) – a prerequisite for compatibility with

the Porsche Stability Management (PSM), which comes as standard. It also regulates all engine-related functions to achieve optimum fuel consumption, emissions and power output whatever the driving style.

Another function is the cylinder-specific knock control. Since the cylinders never all work under exactly the same conditions,

the knock control function monitors each one separately. The ignition point is shifted individually, as and when necessary, to protect the cylinders and pistons at high engine speeds.

For compliance with EU standards, the on-board diagnostics detect any faults and defects that may occur in the exhaust

and fuel systems and then notify the driver immediately. This also prevents increased pollutant emissions and unnecessary fuel consumption.



911 Carrera S with sports exhaust system

The long and winding road is where you'd like to be. Sometimes, it pays to take the direct route.

Transmission.

The new 7-speed manual gearbox.

Pure, direct, precise. Short shift movements and an optimum transition from one gear to the next. That's exactly what you would expect of a Porsche manual gearbox.

What you might not have expected is a 7-speed manual gearbox that combines a high level of sporty performance with an equally high level of efficiency and offers extra comfort for longer journeys.

It's an exceptional innovation, and not only in the sportscar segment.

The design of this manual gearbox is based in principle on that of Porsche Doppelkupplung (PDK). Gears 1 to 6 have a sports ratio and top speed is reached in 6th gear. The additional 7th gear, however, has a long ratio, which reduces torque and helps to reduce fuel consumption. Lower engine revs at fast driving speeds also ensure a high level of comfort on long stretches of road. In addition,

a gear indicator in the rev counter reminds you which gear has been selected. The upshift indicator in the instrument cluster helps you actively conserve fuel.

Thanks to the elevated centre console, the gear lever is within easy reach – ideal for sporty gear changes.

Whether you select a sporty or comfortable gear, the way you reach your destination is in your own hands.



Porsche Doppelkupplung (PDK).

Available as an option for the new 911 models is 7-speed PDK, featuring manual and automatic modes. This double-clutch transmission has been further refined and enables extremely fast gear changes with no interruption in the flow of power,

which vastly improves acceleration at the same time as reducing fuel consumption.

In total, PDK has seven gears at its disposal. Gears 1 to 6 have a sports ratio and top speed is reached in 6th gear. 7th gear has a long ratio and helps to reduce fuel consumption by keeping engine revs low.

PDK is essentially two gearboxes in one and thus requires two clutches. This double-clutch arrangement provides an alternating, non-positive connection between the two half gearboxes and the engine by means of two separate input shafts.

The flow of power from the engine is transmitted through one half gearbox and one clutch at a time, while the next gear is preselected in the second half gearbox. During a gear change, therefore, one clutch simply opens and the other closes at the same time, enabling gear changes to take place within milliseconds.

The effect is instant. Driving feels even sportier and more dynamic, and agility is increased. Depending on the gearshift programme (SPORT button activated or deactivated), the gear change is optimised for comfort or for sporty driving.

With the optional Sport Chrono Package, PDK is enhanced by the 'Launch Control' and 'motorsport-derived gearshift strategy' functions (p. 50).

Coasting.

The 'coasting' function available with Porsche Doppelkupplung (PDK) enables you to save even more fuel where the situation allows. The engine is decoupled from the transmission to prevent deceleration caused by engine braking.

In this way, optimum use is made of the vehicle's momentum, allowing it to coast for longer distances.

For example, you may want to slow down from 100 km/h to 80 km/h in anticipation of the change of speed limit ahead. As soon as you release the accelerator pedal, PDK deselects the current gear automatically and you begin to coast in neutral until you have reached your desired speed. The moment you engage the accelerator or brake pedal, PDK selects the appropriate gear smoothly and seamlessly within a fraction of a second.

Another way to reduce fuel consumption is to utilise the coasting function on downhill gradients that are gentle enough for you to maintain a constant speed. Efficient on long journeys, such as on the motorway, PDK remains ready to respond as swiftly and precisely as you would expect.

In short, driving in coasting mode makes a real impact on fuel consumption without any need for compromise on comfort or sporty performance.

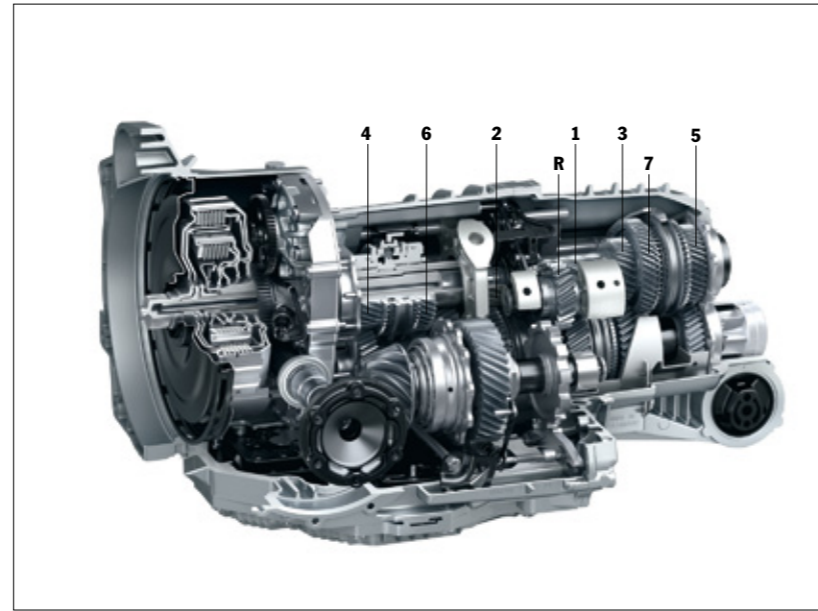

Porsche Doppelkupplung (PDK)



“That can’t be done.”

If ever a sentence gave motivation to sportscar designers, this is it.

Chassis and body.

A solid identity tends to be described with words like stability, directness or substance. This might sound a little serious but, when it comes to the chassis and body, we think that this is entirely the right approach.

The best example is the engineered design. Indeed, dynamic performance and ride comfort fundamentally depend on factors such as vehicle weight, body rigidity, wheelbase, axle construction and steering. With the new 911, we challenged our engineers to push the boundaries of what is possible.

Chassis control systems make a key contribution to the 911 driving experience and thus to the 911 identity. These include (standard in the 911 Carrera S): Porsche Stability Management (PSM), Porsche Active Suspension Management (PASM) and Porsche Torque Vectoring (PTV) or, in conjunction with PDK, Porsche Torque Vectoring Plus (PTV Plus). Porsche Dynamic Chassis Control (PDCC) is additionally available as an option for the 911 Carrera S.

Yet, there is still scope for improvement as far as sporty performance is concerned. The optional Sport Chrono Package triggers an adrenaline rush at the push of a button. Dynamic engine mounts, until now exclusively reserved for 911 GT and Turbo models, may not be capable of breaking the laws of physics but they do succeed in exploiting them to their own advantage – and yours.



Engineered design.

The new 911 fulfils two structural design requirements thanks to its completely new bodyshell: first, excellent driving dynamics due to the body's extremely high rigidity; second, a weight saving of approximately 50 kg in the bodyshell as a result of an intelligent lightweight construction.

To meet the second requirement, we employed innovative and precise techniques for combining various materials in order to utilise specific material properties exactly where they are needed.

For the bodyshell, therefore, we used very thin, but nevertheless extremely rigid, sheets of steel. Aluminium and

magnesium were used extensively in areas such as the roof, underbody, front end, doors, rear wings and engine compartment and luggage compartment lids. Lightweight magnesium was also selected for the cockpit support beam. Such material efficiency is key to reducing the overall weight and, as a result, fuel consumption of the vehicle.

For the driver, this intelligent blend of materials reduces the weight of the vehicle and offers a high level of comfort thanks to excellent vibration-damping characteristics and particularly high composite rigidity, an increase in dynamic torsional stiffness of up to 25% compared with that of the previous model, and even sportier handling despite a further improvement in the weight to power ratio.

The 100 mm longer wheelbase improves comfort as well as straight-line accuracy and driving stability at high speeds and in fast corners.



- Aluminium
- Deep-drawn steels
- Multiphase steels
- Super-high-strength micro-alloyed steels
- Boron-alloyed steels

Front and rear axles.

The redesigned independent suspension at the front features a lightweight spring-strut axle with longitudinal and transverse links and cross members that have been refined for stiffness. Each front wheel is precisely located, ensuring excellent directional stability, superior handling

and increased anti-dive (reduced pitching under braking), and the wider track optimises turn-in.

The rear axle is equipped with a motorsport-derived multi-link suspension and chassis subframe based on the LSA concept (Lightweight, Stable, Agile), which has been modified to offer

improved noise characteristics. Refined axle kinematics for improved longitudinal damping reduce acceleration squat and increase comfort. Lightweight spring struts further enhance agility.

The high proportion of aluminium used in the construction of the axles reduces the weight of the vehicle and of the unsprung

masses, helping to improve fuel economy, comfort and agility.

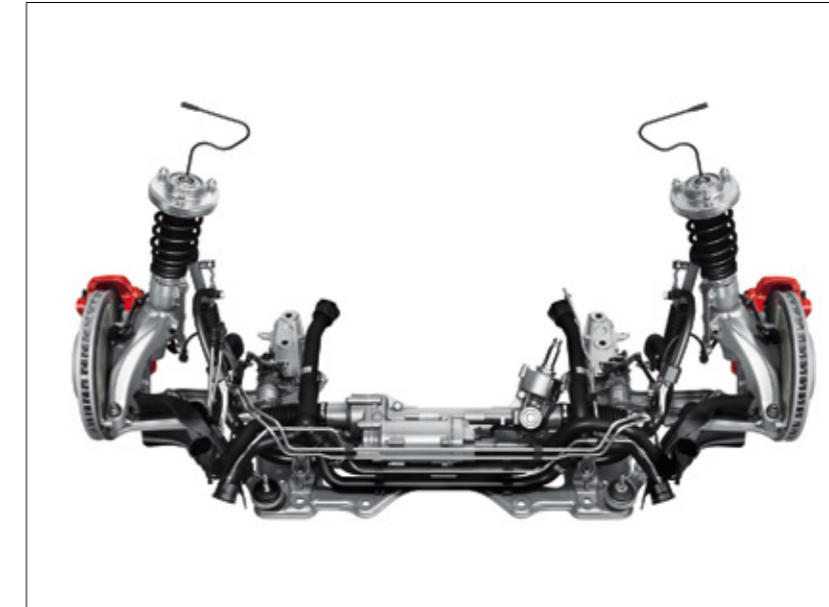

Front axle of the 911 Carrera S

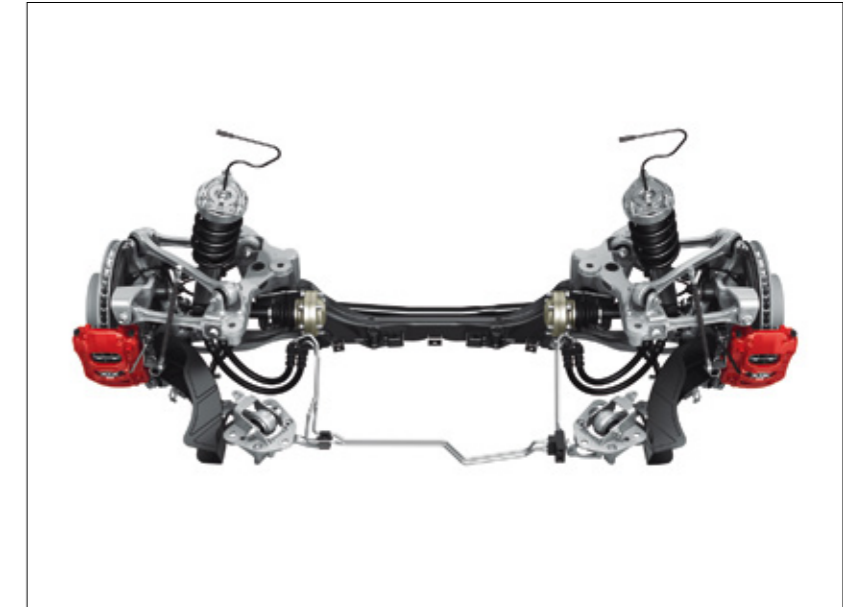

Rear axle of the 911 Carrera S

No need to let the laws of physics spoil your fun.

Porsche Active Suspension Management (PASM).

PASM, the electronic damping control system, is standard in the 911 Carrera S and available as an option for the 911 Carrera. It actively and continuously regulates damping forces according to driving style and road conditions. In addition, the suspension is lowered by 10 mm.

PASM has two modes, which can be selected using a separate button on the centre console: 'Normal', which is a blend of performance and comfort, and 'Sport' where the setup is much firmer.

Sensors record the body movements that accompany powerful acceleration, braking or uneven road surfaces. In the new 911, the number of sensors has been increased for improved data acquisition and even more efficient control interventions. The PASM control unit evaluates the driving conditions and modifies the damping force on each of the wheels in accordance with the selected mode.

In 'Sport' mode, the suspension is set to a harder damper rating. On uneven roads, PASM immediately switches to a softer

rating, thereby improving contact between the wheels and the road. When the road surface improves, PASM automatically reverts to the original, harder rating. If 'Normal' mode is selected and the driver's style becomes more assertive, PASM automatically switches to a harder rating. Damping firms up, and driving stability and road safety are increased.

The results are tangible: increased driving stability, improved comfort and enhanced performance.

PASM sports suspension.

The new PASM sports suspension is available as an option for both models in conjunction with 20-inch wheels and Porsche Torque Vectoring (PTV) or Porsche Torque Vectoring Plus (PTV Plus).

The ride height is 20 mm lower than with the standard suspension or 10 mm compared with the PASM suspension. The springs are harder and shorter, and the anti-roll bars on the front and rear axles are stiffer. The front spoiler lip has a more sporty geometry, the rear spoiler

extends even further. These not only further reduce lift at the front axle, but also provide downforce at the rear axle for improved aerodynamics and even better performance.



**You appreciate directness.
But love a few twists and turns.**

Porsche Dynamic Chassis Control (PDCC).

It's easy, and even makes sense, to carry on in your usual way, but what happens if a sudden change of direction leaves you thrown off course? Then, it all comes down to personal strength.

A Porsche has a clear sense of purpose and is the embodiment of strength. It demonstrates this with sporty and precise handling and excellent road holding.



Rapid cornering in the 911 Carrera without PDCC (illustrative example)

With the optional Porsche Dynamic Chassis Control (PDCC) for the S model of the new 911, these characteristics can be further accentuated: the 911 Carrera S holds the road even better and delivers even sportier performance.

PDCC is an active anti-roll system that anticipates and reduces lateral body movement during cornering manoeuvres. In addition, it minimises the lateral instability of the vehicle on uneven ground.

This effect is achieved with the aid of hydraulic stabilising actuators in the form of cylinders designed to optimise camber. Lateral roll is counteracted by forces generated at each individual wheel, based on steering angle and lateral acceleration.

The results are improved dynamic performance and increased ride comfort at all speeds, as well as optimised turn-in and stable load transfer characteristics.

In simple terms, the vehicle holds the road better and you can steer through corners faster and in a more relaxed manner.

PDCC sets new standards for handling performance, ride comfort and driving pleasure. In the new 911, your 'usual' way suddenly becomes the Porsche way.



Rapid cornering in the 911 Carrera S with PDCC (illustrative example)

Power steering.

Another possible definition of efficiency is a system that works only when it is needed, and then does so in a particularly effective way.

This was the guiding principle for our engineers in the development of the

new electromechanical power steering. Statistics show that a car drives in a straight line 90% of the time. Unlike conventional hydraulic pumps, the electric motor uses energy only when the steering wheel is actually turned. The absence of hydraulic fluid also makes the system more beneficial to the environment.

As far as the other 10% is concerned, we're optimally prepared as the steering system is typically Porsche. It features a variable steering ratio and responds sensitively and directly at the same time as providing customary agility, a high level of comfort and precisely selected feedback from the road. Our definition of efficient.

Power steering Plus.

Power steering Plus, the speed-sensitive power-steering system, is available as an option for the 911 Carrera models. At high speeds, the steering is as firm as you would expect and responds with extreme precision while steering comfort remains as high. At low speeds, the steering ratio of Power steering Plus adjusts for much easier manoeuvring and parking.

Every day can be sports day.**Additional performance enhancement systems.****SPORT button.**

Fitted as standard, the new SPORT button enables you to select a suspension setup where the emphasis is on either comfort or sporty performance. At the push of a button, the electronic engine management system switches the engine mapping to offer an even sharper response and engine dynamics that are more direct.

In vehicles with Porsche Doppelkupplung (PDK), upshifts take place at higher engine speeds and downshifts happen

sooner. In addition, coasting mode and the auto start/stop function are automatically deactivated. If fitted, the optional sports exhaust system is also activated automatically.

Sport Chrono Package.

The Sport Chrono Package including dynamic engine mounts is available as an option. This integrated system provides simultaneous enhancement for the chassis, engine and transmission.



Included in the package are a performance display, a digital and an analogue stopwatch and the SPORT PLUS button. An additional display in the steering wheel and instrument cluster indicates whether the SPORT buttons and Launch Control have been activated.

On activation of SPORT PLUS mode, Porsche Active Suspension Management (PASM) and, in the S model, optional Porsche Dynamic Chassis Control (PDCC) switch to a harder damping setting and offer more direct steering and, therefore, better road holding.

In SPORT PLUS mode, the trigger threshold for PSM is raised. Agility is perceptibly enhanced when braking for corners with PSM, allowing sportier braking and exit acceleration. For maximum dexterity, PSM can be set to standby while the car is still in SPORT PLUS mode. For safety, it is set to intervene automatically only when ABS assistance is required on both the front wheels.

In combination with PDK, the Sport Chrono Package has two additional

functions for a sporty drive that borders on a motorsport experience. The first is 'Launch Control', which can be used on the track to achieve the best possible standing start – a racing start.

The second function is the 'motorsport-derived gearshift strategy'. Using this, Porsche Doppelkupplung (PDK) is geared up for extremely short shift times and

optimum shift points for the maximum acceleration available. This combination of uncompromising and involving performance is ideal for the racetrack.

A key component of the Sport Chrono Package is the stopwatch mounted on the dashboard. In conjunction with the optional PCM, a special performance display enables you to view store and

evaluate lap times or other driving times. It shows the total driving time, lap distance, lap number and lap times recorded so far.

A feature of the Sport Chrono Package borrowed from motorsport is the dynamic engine mounts. These exploit the laws of physics for your own driving pleasure.



Dynamic engine mounts.

You don't have to take the new 911 onto the racetrack. But you can, more so than ever, because dynamic engine mounts are now included as part of the Sport Chrono Package. Based on the engine mounts of the 911 GT3 and 911 Turbo models, it is the first time

that they have been available for the 911 Carrera. Even if track racing is not for you, dynamic engine mounts make a decisive contribution to dynamic performance on the road, too.

The electronically controlled system minimises the oscillations and vibrations of the entire drive train, especially the engine.

The engine is bolted to the body by two mounts. Like any mass, it obeys the law of inertia. This means that it will continue moving in a uniformly straight line unless some force causes it to change direction. Put more simply: when you are driving into a bend, the vehicle will follow your steering but, at first, the mass of the engine will not. This means that the rear of the vehicle will ultimately be pushed outwards as a result of the engine's force of inertia.

Dynamic engine mounts minimise this effect. Steering angle and both longitudinal and lateral acceleration are constantly recorded by sensors. The stiffness and damping performance

of the engine mounts adapt to changes in driving style and road surface conditions, which is achieved by use of a fluid magnetised in an electrically generated field. This results in greater traction and perceptibly more stable handling under load change conditions and in fast corners.

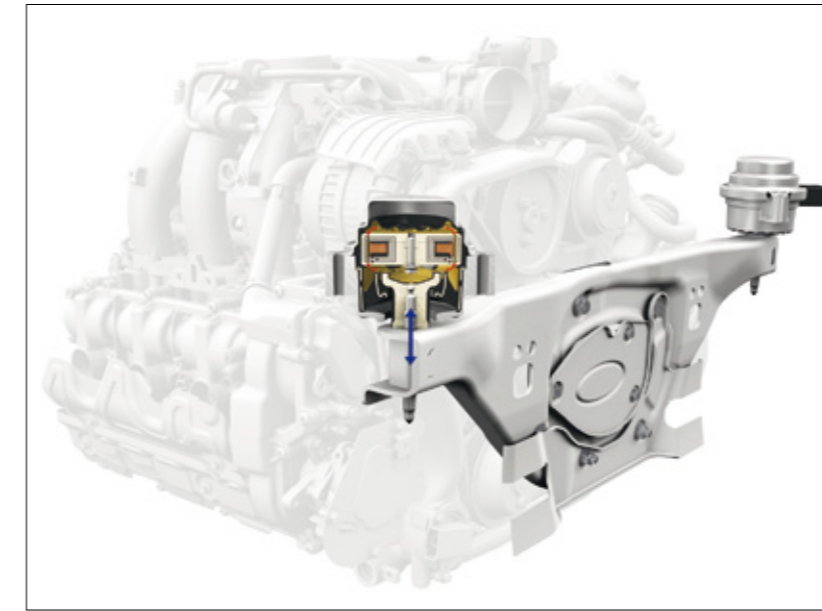

Wheels.

On the new 911, the wheels have been enlarged by one inch over the previous model. Not only do the larger wheels improve dynamic performance, they also look more imposing.

The new 911 Carrera is equipped with 19-inch Carrera wheels as standard.

These are lightweight alloys featuring a classic sporty design. Tyre sizes are 235/40 ZR 19 and 285/35 ZR 19 at the front and rear respectively.

The S model is equipped with light-alloy 20-inch Carrera S wheels as standard. The visual effect is sporty and dynamic. The tyres are slightly wider to cope with the increased power output of this

model: 245/35 ZR 20 at the front, 295/30 ZR 20 at the rear.

The larger tyre size improves both ride comfort and track performance. The rolling resistance of the summer tyres has been reduced by up to 7% to improve fuel economy, while tyre weight and dry braking distances have also been reduced.

A selection of 20-inch wheels is available in our range of options.



911 Carrera S with 20-inch Carrera Classic wheels



19-inch Carrera wheel (standard on the 911 Carrera)



20-inch Carrera S wheel (standard on the 911 Carrera S)

Tyre Pressure Monitoring (TPM).

Tyre Pressure Monitoring (TPM) is available on request. This safety system sends warnings to the on-board computer's display screen in the event of low tyre pressure or a gradual or sudden loss of pressure. The individual pressures in all four tyres can be displayed in the instrument cluster.

Porsche Stability Management (PSM).

As standard, the new 911 models are equipped with enhanced Porsche Stability Management (PSM), which maintains stability even at the limits of dynamic driving performance. Sensors continuously monitor the direction, speed, yaw velocity and lateral acceleration of the car. Using this information, PSM

is able to calculate the actual direction of travel at any given moment. If the car begins to oversteer or understeer, PSM applies selective braking on individual wheels to restore stability.

Under acceleration on wet or low-grip road surfaces, PSM improves traction using the automatic brake differential (ABD), anti-slip regulation (ASR) and

engine drag torque control (EDC) function. When the SPORT PLUS mode of the optional Sport Chrono Package is selected, the PSM threshold is raised to allow a sportier driving style.

For an even more dynamic experience, you always have the option to deactivate PSM. It is automatically reactivated, for your safety, only if you brake harder and either of the front wheels (in SPORT PLUS mode, both of the front wheels) requires ABS assistance. ABS and ABD, however, remain active at all times.

PSM therefore offers a high level of driving stability and safety combined with extraordinary agility. It's an apparent contradiction in terms, but an intrinsic part of the Porsche identity.



Attack the corners. Maintain good posture.

Porsche Torque Vectoring (PTV) and Porsche Torque Vectoring Plus (PTV Plus).

PTV in conjunction with the manual gearbox, or PTV Plus with Porsche Doppelkupplung (PDK), are available as options for the 911 Carrera and standard in the 911 Carrera S. Both systems actively enhance vehicle dynamics and stability. Operating in conjunction with a mechanical (PTV) or electronic (PTV Plus) rear differential lock, they work by braking the rear wheels as the situation demands.

As a function of steering angle and steering speed, accelerator pedal position, yaw rate and vehicle speed, PTV and PTV Plus

are able to improve steering response and steering precision by specific braking of the right or left rear wheel.

To be more precise, this means that when the car is driven assertively into a corner, moderate brake pressure is applied to the inside rear wheel. Consequently, a greater amount of drive force is distributed to the outside rear wheel, inducing an additional rotational pulse (yaw movement) around the vehicle's vertical axis. This results in a direct and sporty steering action as the car enters the corner.

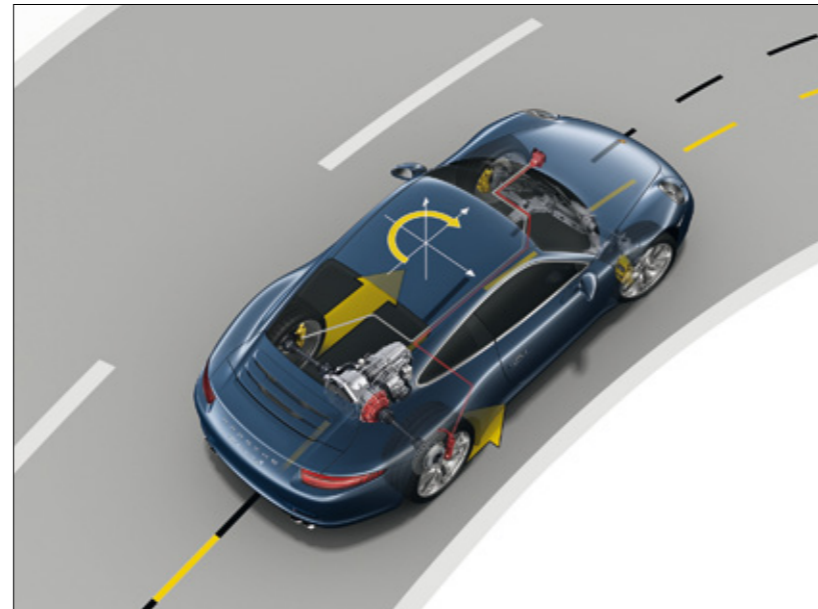

At low and medium vehicle speeds, PTV and PTV Plus significantly increase agility and steering precision. At high speeds and when accelerating out of corners, the rear differential lock ensures greater driving stability. With PTV, the differential lock is regulated mechanically; with

PTV Plus, it is regulated electronically and the torque distribution is infinitely variable. Whichever system is fitted, it interacts with Porsche Stability Management (PSM) to improve driving stability on a range of surface conditions, including the wet and snow.

For the driver, this means remarkable stability, easier handling and outstanding traction as well as greater agility at every speed with precise steering and stable load transfer characteristics. What else? Unrivalled driving pleasure at every twist and turn.





discerning
foresighted
intuitive
uncompromising
tenacious
Composure
balanced
precise
controlled

Control, discipline, precision.

At Porsche, we take driving pleasure very seriously.

Safety.

Brakes.

Another crucial piece of the Porsche identity is the brakes. We value them as highly as we do our engines and chassis. They set standards for deceleration and stability, and give the driver the reassurance needed to push the car to the limits of its performance.

The 911 Carrera is fitted front and rear with anodised black four-piston aluminium monobloc fixed calipers. All brake discs have a diameter of 330 mm.

On the 911 Carrera S, we have fitted larger brakes and more brake pistons to

cope with the increased engine power of this model. The new generation of brakes features red six-piston monobloc aluminium fixed brake calipers at the front and four-piston aluminium monobloc fixed calipers at the rear. The brake disc diameter is 340 mm at the front and 330 mm at the rear. The results are enhanced braking performance and a reduction in stopping distance compared with that of the previous model.

On all models, the brake calipers have an enclosed monobloc construction. This makes them tougher but lighter and enables a more rapid response and release of the brake even under extreme

loads. The pedal travel is short and the biting point precise. The brake discs are cross-drilled for better performance in the wet.

Other benefits of the standard braking system include the anti-lock braking system (ABS), designed to keep deceleration constant. Pedal effort is reduced and braking response improved by a newly developed 8-/9-inch tandem vacuum brake booster. In the S model, brake disc cooling is further enhanced by modified air spoilers.



Standard brake system on the 911 Carrera



Standard brake system on the 911 Carrera S



What we've discovered from over 28,000 racing victories: Brake later, finish sooner.

Porsche Ceramic Composite Brake (PCCB).



From the start, Porsche has been synonymous with motorsport. Ever since 1948, when we found our identity on the racetrack, we have taken the experience we have gained and applied it to the road. The optional Porsche Ceramic Composite Brake (PCCB) is a fine example. This brake system has already had to cope with the harshest requirements of

motor racing and is fitted in cars that compete in demanding events such as the Porsche Mobil 1 Supercup.

The cross-drilled PCCB ceramic brake discs for the new 911 have a diameter of 350 mm front and rear for even more formidable braking performance.

The use of six-piston aluminium monobloc brake calipers on the front axle and four-piston units at the rear – all finished in yellow – ensures extremely high brake forces which, crucially, are exceptionally consistent.



PCCB enables shorter braking distances in even the toughest road and race conditions. Excellent fade resistance ensures greater balance when slowing from racetrack speeds.

The key advantage of PCCB is the extremely low weight of the ceramic brake discs, which are approximately 50% lighter than standard discs of similar design and size. As well as enhancing performance and fuel economy, this represents a major reduction in unsprung and rotating masses. The consequence of this is better road holding and

increased comfort, particularly on uneven roads, as well as greater agility and improved handling.

Please note that circuit racing, track day use and other forms of performance driving can significantly reduce the service life of even the most durable brake pads and discs.

As with conventional high-performance braking systems, we recommend that all brake components be professionally inspected and replaced where necessary after every track event.

Electric parking brake.

The new electric parking brake, which you can activate and deactivate manually, releases automatically as you pull away.

With the hill-hold function, you can pull away without ever rolling back. The system automatically detects when the vehicle has come to a halt on an uphill gradient requiring intervention. PSM then maintains the brake pressure at all four wheels for a brief period to prevent the vehicle from moving in the opposite direction.



Airbags.

The new 911 models offer advanced airbag technology in the form of full-size driver and front passenger airbags, which are inflated in two stages depending on the severity and type of accident (e.g. frontal or offset frontal). In less serious accidents, the airbags are only partially inflated, thereby minimising discomfort to the occupants.

In addition to the central airbag control unit on the transmission tunnel, a pair of impact sensors are located near the headlights. This allows a crash to be detected and evaluated far sooner and with considerably greater accuracy.

Porsche Side Impact Protection System (POSIP).

The 911 Carrera and 911 Carrera S are equipped as standard with the Porsche Side Impact Protection System (POSIP). It comprises side impact protection elements in the doors and two airbags

on each side. An integral thorax airbag is located in the seat backrests, while the door panels each contain an upwards-inflating head airbag. Each thorax airbag has a volume of 10 litres and each head airbag 15 litres, ensuring excellent protection in the event of a side impact.

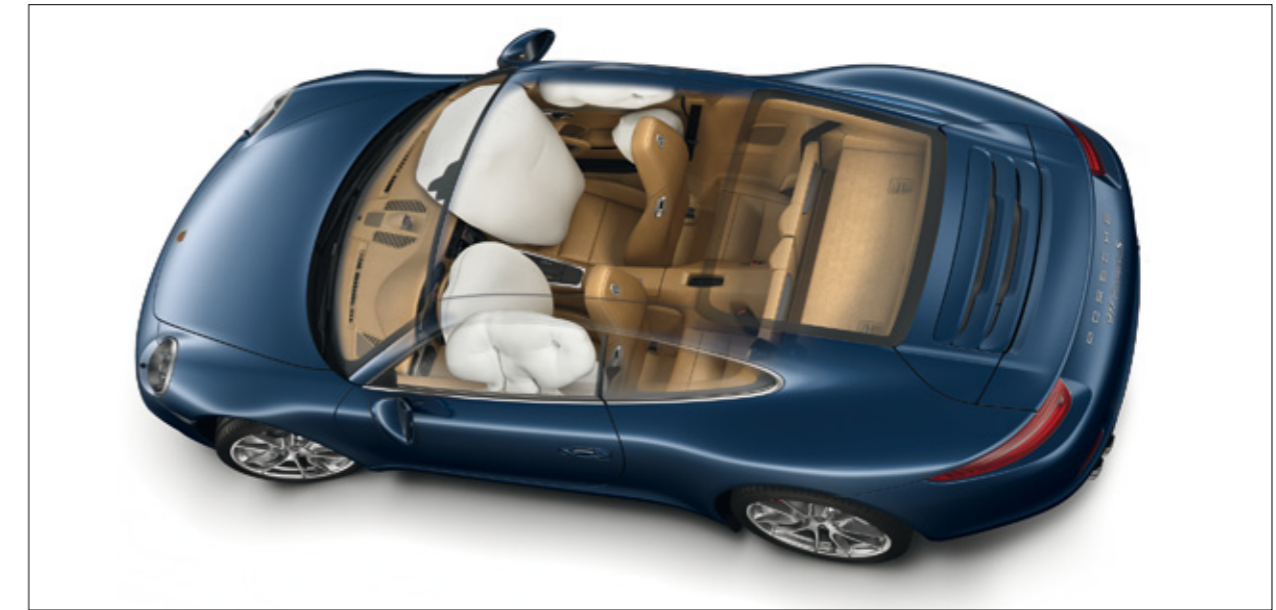

To see something coming, experience helps. So does forward-looking technology.

Lights.

The 911 Carrera and 911 Carrera S are both equipped as standard with Bi-Xenon headlights including a headlight cleaning system and dynamic range control. With dipped or main beam, the road ahead is illuminated more uniformly.

The restyled LED front light units incorporate direction indicators, daytime-running lights and position lights.

Both 911 models come with automatic headlight activation. The moment it gets dark, the daytime running lights switch off and the dipped beam headlights switch on automatically.

Cutting edge LED technology is also used for the taillights, the high-level third brake light, the licence plate illumination, the rear direction indicators and the rear fog light. LEDs provide better illumination and respond more quickly to driver input. In the event of sudden braking, the adaptive LED brake lights begin to pulsate. If the vehicle is braked to a halt, the hazard warning lights will switch on automatically, alerting following traffic more quickly to a critical situation.

The lighting system features an automatic switch-off and the 'Welcome Home' function. It's good to know what's around the next corner or on the way to your front door.



Porsche Dynamic Light System (PDLS) headlights



Taillights and high-level third brake light



Porsche Dynamic Light System (PDLS) cornering lights

Porsche Dynamic Light System (PDLS).

The Porsche Dynamic Light System (PDLS) is available as an option for both models.

Its dynamic cornering light function swivels the headlights towards the inside of a bend, based on steering angle and

road speed, in order to illuminate more of the road at tight bends and turns. Put simply, the road ahead is illuminated the moment you enter a bend.

The system also offers speed-sensitive headlight range control. With adaptive light systems, it is possible for the maximum range of the dipped beams to be

increased as a function of the speed of the vehicle. PDLS takes care of this automatically in two stages. Stage 1 is the basic position for driving in city traffic, for example. Stage 2 is designed for driving at faster speeds, such as on the motorway. Above 130 km/h, the range is adapted again.

Another feature of PDLS is the adverse weather function, activated whenever the rear fog light is switched on. It reduces the effect of reflection phenomena in poor visibility conditions to avoid the risk of the driver being dazzled.

**Our identity is found under the bonnet,
in the design and behind the steering wheel.**

Comfort.

Driving a 911 is first and foremost about the feel of the road in the original, unadulterated and direct sense. Is it possible, then, to mention the 911 and comfort in the same breath? To speak of systems that make driving 'more agreeable', or of materials that feel 'pleasant' to the touch? Good question.

In reality, however, should anyone really be forced to choose one over the other? Let's introduce ourselves to the concept of sporty comfort – dynamic performance that maintains composure even when pushed to the extreme.

Interior.

Engineering and style – and Porsche identity on the inside, as demonstrated by the new elevated centre console. In typical Porsche fashion, the use of form follows a basic principle: focus on the driver. This is why the distance between the gear lever or selector and steering wheel is extremely short and the operating logic, such as that of the two-zone air conditioning system or the suspension settings, is clear and uncomplicated. You shouldn't have to browse one submenu after another. You should instead be able to concentrate on what's important: the road.

All our materials are high quality. Sporty and elegant leather is used, for example, on the steering wheel rim, on the door handles and armrests and on the partial leather seats, which are fitted as standard. Alcantara has proven its worth in motorsport and is used as standard for the rooflining.

In addition to the choice of Black, Platinum Grey, Luxor Beige and Yachting Blue for the interior, there is a wide range of other personalisation options available, including two-tone colour combinations or special colours and materials such as carbon, aluminium or high-quality wood.



Engineering that takes you forward: optional Porsche Communication Management (PCM) with navigation module and a high-resolution 7-inch colour touchscreen. PCM is your control centre for audio, navigation and communication functions.

Another element of the Porsche identity is sound. Fitted as standard, the CDR-31 audio system with 7-inch colour touchscreen and the Sound Package Plus offer outstanding performance with a total output of 235 watts. Available as an option is the BOSE® Surround Sound System with a total output of 445 watts. In short, it delivers authentic audio playback combined with an impressive spatial sound.

No system promises such high standards in the 911, and fulfils them, as the optional High-End Surround Sound System from Burmester®, the bespoke manufacturer based in Berlin and one of the most respected premium audio manufacturers worldwide. With a total output of 821 watts, it ensures an incredible audio experience.

Our patented integral subwoofer enhances the bass performance of both optional sound systems and also saves weight. Typically Porsche.

Ergonomics, style and sound. Sportscar technology, intelligently combined.

Instruments.

Sporty not kitsch, practical not fanciful. The dial faces of the five circular instruments have one purpose above all: to provide information. They do so efficiently and accurately. Their styling is typically Porsche with the rev counter exactly where you would expect it to be: in the middle.

The instrument cluster is new with a high-resolution 4.6-inch TFT colour screen. It provides you with a continuous stream of data from the on-board computer, such as speed, trip mileage, journey time or current fuel consumption. It also displays the navigation system map, delivers various warnings, including alerts from

the Tyre Pressure Monitoring (TPM) system, and reminds you of your selected communication and audio settings.



Instruments in the 911 Carrera S with aluminium-coloured rev counter



TFT display

In the 911, there is a point at which all forces come together. The steering wheel is the most important interface between the driver and the sportscar. This is why all available steering wheels feature a high-grip steering wheel rim in smooth-finish leather and offer outstanding ergonomics. A full-size airbag is integrated as standard.

Sports steering wheel.

The sports steering wheel is fitted as standard and adjusts up to 40 mm for height and up to 60 mm for reach.

The optional multifunction steering wheel has four function buttons and two

thumbwheels for convenient operation of audio, telephone and navigation functions, TFT display and on-board computer. On request, the steering wheel is available in smooth-finish leather, Aluminium Look, carbon or macassar.

In conjunction with PDK, the steering wheels are equipped with two ergonomic gearshift switches enabling you to change gear directly from the steering wheel. With the optional Sport Chrono Package, the steering wheel also features a display above the airbag module to inform you whether the SPORT, SPORT PLUS and Launch Control functions have been activated.

SportDesign steering wheel.

As with the sports steering wheel, the optional SportDesign steering wheel is adjustable for both height and reach and, thanks to its grip mouldings, it's in safe hands – even on the sportiest of drives.

In conjunction with PDK, the steering wheel features two gearshift paddles. These are made from a strong alloy and are ergonomically located behind the left- and right-hand steering wheel spokes. Pull the right-hand paddle and PDK shifts up. Pull the left-hand paddle

and PDK shifts down. When PDK has been combined with the optional Sport Chrono Package, the left- and right-hand spokes additionally feature a display that tells you whether the SPORT, SPORT PLUS and Launch Control functions have been activated.

Steering wheel heating.

For increased comfort on cold days, steering wheel heating is available as an option for the sports steering wheel and multifunction steering wheels (only in conjunction with seat heating).

The heating is operated by a button on the rear of the lower steering wheel spoke.



Sports steering wheel



Multifunction steering wheel in conjunction with PDK



SportDesign steering wheel with gearshift paddles



SportDesign steering wheel

The ideal basis for any relationship: Support as well as freedom.

Seating.

Sports seats.

The Sports seats in partial leather are comfortable and provide support even during performance driving. They are equipped as standard with electric seat height and backrest adjustment and mechanical fore/aft adjustment.

Sports seats Plus.

Available as an option are Sports seats Plus in leather with electric seat height and backrest adjustment as well as mechanical fore/aft adjustment. The side bolsters on the squab and backrest have a firmer, sportier padding and offer even better lateral support. The backrest shell is finished in Silver Grey.

Fully electric Sports seats.

If you don't want to sacrifice sportiness for comfort, the optional fully electric Sports seats offer fully electric adjustment of seat height, backrest angle, squab angle, squab depth, fore/aft position, 4-way lumbar support and even the steering column.

The integrated memory package supports the exterior mirrors and all seat positions on the driver's side as well as settings for the steering wheel, lights, wipers, air conditioning, door locks, optional PCM, and instrument cluster.

Adaptive Sports seats Plus.

The optional adaptive Sports seats Plus are the ideal combination of sport and comfort. Finished in leather and with side bolsters having a firm, sporty padding, they also feature shoulder supports for the best possible hold.

Offering 18-way electric adjustment, the seats can be optimally adapted to meet your needs in terms of seat height, squab and backrest angle, squab length, fore/aft adjustment and 4-way lumbar support. The steering column is also electrically adjustable.

In addition, the side bolsters on the seat squab and backrest are independently adjustable for added comfort on long journeys and precision lateral support on winding roads. Also included is the personal memory for all seat positions (apart from the side bolsters) and lumbar support on the driver's side as well as the positions of the steering wheel and

exterior mirrors. The memory function also supports settings for the steering wheel, lights, wipers, air conditioning, door locks, optional PCM, and instrument cluster.



Adaptive Sports seat Plus

Seat heating and ventilation.

Seat heating is available as an option for all seats. Seats are heated in the squab, the backrest and, for the front seats, the side bolsters.

In conjunction with seat heating, we can equip the seats with seat ventilation on request. A slipstream effect is produced by active ventilation of the perforated seat centre and backrest and by passive aeration at the side bolsters. This evaporates perspiration moisture and therefore makes for a dry and pleasant seating environment, even in hot weather.

Rear seats.

The rear seats are remarkably comfortable for a sports car and the shelf behind offers additional storage space. The backrests fold as standard to offer a generous 205 litres of luggage space in the rear.

Child seats.

ISOFIX child seat preparation including top tether is available on the rear seats as standard. On request, we can equip the front passenger seat with ISOFIX child seat preparation and integrate an airbag deactivation feature.

**Many things have practical qualities.
Even more have a sporty function.
And some are just extremely convenient.**

Additional comfort and convenience features.

Climate control.

Both 911 models feature two-zone automatic climate control as standard with an enhanced ventilation effect and separate temperature controls for the driver and front passenger. The available air conditioning modes are gentle, normal and strong.

An active carbon filter traps particles, pollen and odours and an automatic air-recirculation function permanently monitors air quality, reduces humidity and switches from fresh to recirculated air when required.

A demister function keeps the windows clear in cold weather. In warmer weather, a solar sensor helps the climate control to detect strong sunlight and automatically compensate for the comfort of both the driver and front passenger.

HomeLink® (programmable garage door opener).

As an option, it is possible to have a programmable garage door opener integrated into the overhead console. At the push of a button, it controls up to three different garage doors, lighting systems or alarm systems.

'Welcome Home' lighting.

For convenience, particularly at night, the 'Welcome Home' lighting function automatically switches on the LED daytime running lights for a defined period whenever the vehicle is opened or closed using the key remote.

A customisable delayed switch-off timer keeps the daytime running lights, the taillights and, where applicable, the courtesy lights switched on until you reach your front door.

Cruise control.

This automatic speed control function is available as an option. For greater driver comfort on long stretches of road, cruise control operates in the 30–240 km/h speed range and is activated using a button on the steering column control stalk.

ParkAssist.

The optional ParkAssist features four inconspicuous sensors in the rear end. The system audibly alerts the driver to the presence of obstacles detected behind the vehicle. An intermittent warning tone increases in rapidity as the obstacle is approached.

An enhanced version of ParkAssist, with four sensors in the front end, is available on request. The audible alert is supplemented by a visual warning in the central display screen, which shows a graphical representation of the vehicle from overhead.

Light design package.

The optional light design package is both practical and aesthetically appealing. It comprises dimmable LEDs in the door panels, overhead console, footwells, ignition lock and rear compartment.



ParkAssist (front)



ParkAssist (rear)

Exterior mirrors and rear-view mirror.

The most prominent new feature of the electrically adjustable exterior mirrors is their position. They are mounted directly on the doors for improved aerodynamics.

Electrically folding exterior mirrors with courtesy lighting on both sides of the

vehicle are available as an option. By illuminating the area in front of the doors, they make it easier to find your way in the dark.

An auto-dimming function for the rear-view mirror and exterior mirrors, with an integrated rain sensor for the windscreen wipers, is available as an option.

**Slide/tilt sunroof.**

The optional electrically adjustable slide/tilt sunroof is a completely new design. It opens outwards so that it does not interfere with headroom. Another advantage of the new design is the much larger aperture for increased driving pleasure under the open sky.



The newly developed two-position net-type wind deflector protects against draught and minimises wind noise. Even humming disturbances are eliminated, whatever your speed of travel.

Roof transport system.

The optional aluminium roof transport system is aerodynamically efficient, very lightweight and easy to fit. A range of attachments is available, such as a roof box, a bike carrier or a ski/snowboard carrier. Maximum roof load is 75 kg.

**Luggage compartment.**

The luggage compartment volume in the new 911 models is 135 litres. The luggage compartment is fully trimmed in scratch-resistant materials.

Porsche Entry & Drive.

With the optional Porsche Entry & Drive, you can leave your car key in your pocket. As soon as you touch the door handle or the Porsche Crest on the luggage compartment lid, the system automatically checks the encrypted access code on the key. Once the key is validated, the door or the luggage compartment lid

unlocks. The engine can then be started and switched off using the electronic ignition switch.

To lock the vehicle, you simply press the button on the outside of the door handle. Porsche Entry & Drive then locks the vehicle and activates the engine immobiliser and steering column lock.

Anti-theft protection.

All 911 Carrera models are equipped as standard with an immobiliser with in-key transponder and an alarm system with radar-based interior surveillance. The system secures the doors, luggage compartment, passenger compartment and ignition lock.

Preparation for Porsche Vehicle Tracking System (PVTs).

Available as an option, this preparation enables future installation of the Porsche Vehicle Tracking System (PVTs) available from Porsche Tequipment. The system makes it possible to locate a stolen vehicle across most of the countries of Europe. The preparation package includes a special wiring loom and a tilt sensor for the alarm system.

Identity is to do with where you come from. Sometimes, it's also to do with where you want to be.

Audio and communication.

CDR-31 audio system.

Fitted as standard, the CDR-31 audio system features a 7-inch colour monitor that also acts as a touchscreen, giving you quick and easy access to the most important functions and menus.

The integrated CD radio supports MP3 playback and features an FM dual tuner with RDS, 30 memory presets, dynamic autostore and speed-sensitive volume control. Sounds good. On request, the

CDR-31 audio system can be combined with the BOSE® Surround Sound System or Burmester® High-End Surround Sound System. Sounds even better.

Sound Package Plus.

The Sound Package Plus is fitted as standard. The system comprises a separate amplifier with a total output of 235 watts, seven amplifier channels and nine loudspeakers, all of which combine to create the perfect interior sound experience.



CDR-31 audio system

Porsche Communication Management (PCM) including navigation module.

Porsche Communication Management (PCM) is available as an option for the 911 models. Powerful, multifunctional and easy to use, PCM is your control centre for audio, navigation and communication functions.

The main feature is the intuitive 7-inch touchscreen. Alternatively, you can choose to operate PCM using conventional rotary pushbutton controls. With a maximum of five list items per page, the screen display is very clearly presented. A useful help function is displayed at the foot of the screen.

Radio functions include up to 42 memory presets and an FM dual tuner frequency

diversity with RDS, which continuously scans in the background for the best signal, and a dynamic autostore.

The DVD-audio drive plays CDs and audio DVDs and is MP3-compatible. Audio playback of video DVDs is also supported. A six-disc CD/DVD autochanger integrated into PCM is available as an option.

A navigation module with high-speed hard drive is included with PCM. For route guidance, it is possible to select between a 2D display and a 3D perspective. In some regions, even land and buildings can be displayed in 3D. Split screen mode enables you to view two functions at once, such as the current navigation map and a list of symbols that represent the next driving manoeuvre.

Voice control system.

If you require route guidance, need to make a phone call or want to listen to the radio, then why not just say so? Almost all of the functions of PCM can be controlled using the optional voice control system with word-by-word input. In the majority of cases, you can simply say the name of the menu item as seen on the screen. Even lists can be browsed by voice command. For added convenience, there is no need to 'train' the system.

Electronic logbook.

An electronic logbook is available for PCM as an option. It enables automatic logging on every journey of mileage, route distance, date, time, starting location and destination. Data can be downloaded to a USB stick and evaluated on your home PC using the software supplied. The software fulfils all statutory requirements for automatic logbooks as specified by the German revenue authorities.



Porsche Communication Management (PCM) including navigation module, electronic logbook

Telephone module.

The optional quadband GSM telephone module offers convenience and excellent reception. By inserting a SIM card directly into the PCM's integral SIM card reader, calls can be made using the hands-free facility. For even more convenience, the Bluetooth® capability of a mobile phone can be used to make calls via the SIM Access Profile (SAP).* Once automatic pairing is complete, the mobile phone's aerial is switched off to conserve battery charge and the phone operates via the car aerial. Depending on the mobile phone model, this gives access not only to the numbers on the SIM card, but also to the phone's internal memory. Depending on the phone, it can also be controlled using PCM, the optional multifunction steering wheel or the optional voice control system, without it ever leaving your pocket.

The telephone module also enables you to establish a Bluetooth® link with those mobile phones that only support the Handsfree Profile (HFP). In this case, the GSM connection is always established through the aerial of the mobile phone.* PCM acts as a hands-free system and you can leave the mobile phone tucked away.

On request, a cordless handset for the telephone module is also available. Stored in the centre console, it features a display and keypad. However, the handset cannot be used for Bluetooth® links established using the Handsfree Profile (HFP).

TV tuner.

The optional TV tuner is capable of receiving unencrypted analogue and digital television broadcasts (DVB-T) to provide entertainment between journeys. For your safety, the TV picture is switched off while the car is in motion.



TV tuner

Mobile phone preparation.

To enable a Bluetooth® connection for those mobile phones that only support the Handsfree Profile (HFP),* an optional mobile phone preparation is available. It enables you to leave your mobile phone tucked away. CDR-31 audio system and

PCM are able to control only the basic functions of the mobile phone. The GSM connection is established through the aerial of the mobile phone.*

Universal audio interface.

With this feature, the CDR-31 audio system is supplemented by an AUX interface (e.g. for connecting a compatible MP3 player) installed in the glove compartment. In conjunction with the optional PCM, a USB port is included to enable you to

connect your iPod® or any other compatible audio source of your choice. Recharging is also supported. The iPod® or USB stick can be controlled conveniently and safely using PCM, the optional multifunction steering wheel or the optional voice control system. Through the USB port, it is also possible to download data from

the performance display of the Sport Chrono Package as well as data from the electronic logbook.



Universal audio interface

* Please refer to the notes on page 112.

**Character is conveyed by a clear voice,
not a loud one.**

BOSE® Surround Sound System.

The sound of a Porsche is a unique characteristic, and we're not referring only to the engine. The optional BOSE® Surround Sound System was specially developed for the 911 and is therefore perfectly tuned to the car's specific interior acoustics.

The system is compatible with both Porsche Communication Management (PCM) and the CDR-31 audio system.

It has a total output of 445 watts and comprises 8 amplifier channels, 12 loudspeakers and a patented integral 200-watt active subwoofer. The combined

effect is a balanced acoustic pattern that transforms your 911 into a fast-moving concert hall.

In combination with Porsche Communication Management (PCM), the BOSE® Surround Sound System enables audio playback of DVDs and is thus able to make full use of the impressive sound spectrum of 5.1 digital recordings. Of course, you can still play other audio sources, such as CDs and MP3s, in stereo or, at the push of a button, in one of the virtual surround modes generated by BOSE® Centerpoint® 2.

The BOSE®-patented AudioPilot® noise compensation technology uses a microphone to continuously measure the ambient noise inside the vehicle and adapts music playback instantly and automatically so that a consistent sound is maintained – whatever the driving conditions.

The result is a balanced, faithfully reproduced sound and captivating 360° acoustic experience.

Cue the applause.



Words can barely describe the 911 experience. Sound can.

Burmester® High-End Surround Sound System.

When two iconic German manufacturers join forces, the result is special. We're referring to Porsche and Berlin-based Burmester®, one of the most respected manufacturers of high-end audio equipment worldwide, and the Burmester® High-End Surround Sound System. The technologies behind the system are based on the finest premium home audio systems Burmester® has to offer. The system owes its eminence to countless details, and one goal: perfection in sound.

The system has 12 amplifier channels with a total output of more than 821 watts, 12 loudspeakers including an active subwoofer with 300-watt class D

amplifier, a total diaphragm surface area of more than 1,340 cm², and a frequency response of 35 Hz to 20 kHz.

For the first time in a 911, Burmester® has introduced the patented integral subwoofer, which replaces the familiar separate subwoofer and loudspeaker arrangement of other systems. This saves weight and has a beneficial impact on acoustic performance.

Crossover technology has been carried over more or less unmodified from the home audio sector. Analogue and digital filters have been optimally defined for their new installation location and finely tuned after extensive in-car audio testing.

The tweeters are ribbon-based air motion transformers (AMT) that have been designed specifically for the 911. For unmistakably fine, clear and undistorted high-frequency sound reproduction with excellent level stability. All loudspeaker housings are perfectly matched and deliver superior bass foundation, definition and impulse accuracy. As yet unequalled in the 911, the result is a natural and richly textured spatial sound even at top volume.

The pure, sporty design with galvanised surrounds and Burmester® logos on selected loudspeakers make it clear that the appeal of the Burmester® High-End Surround Sound System is as much

about the visual as it is the audio. Typically Porsche.

Cue the encore.





optimistic
spirited
inventive
realistic
Responsibility
principled
agile
alert
intelligent

On the racetrack, we're fiercely committed. Not least to the future.

Motorsport.

How does one book one's place in motorsport history? By finishing that crucial one hundredth of a second faster than the competition, or a whole lap ahead of the rest of the field? Either way, victory is sweet. At Porsche, however, one goal matters above all: turning to the next chapter and shaping the future of motorsport using intelligent technologies and unconventional ideas with the incentive of increased power output and enhanced efficiency, as well as the ability to incorporate these innovations into cars engineered for the road.

918 RSR race laboratory.

How powerful can a hybrid be? How sustainable can a racecar be? If hybrid sports-car technology is to be taken seriously, we believe it must prove its worth in the testing environment of tomorrow – on the racetrack. The 918 RSR succeeds, lap after lap.

The drive system comprises a high-revving combustion engine, two electric machines on the front axle and enhanced flywheel energy storage derived from the 911 GT3 R Hybrid.

What did we wish to achieve? Extremely high performance, of course, but we also wanted a glimpse of the future. A little bit sooner and a little bit faster.

911 GT3 R Hybrid.

It took a whole year's work for just one day: the 24 Hours of Nürburgring in 2010. With the 911 GT3 R Hybrid, our engineers sent a 911 onto the track equipped for the first time ever with three drive units.

The principle is to recover unused kinetic energy. Energy is stored by a flywheel accumulator that spins at up to 40,000 rpm. After braking, two electric motors on the front axle enable the driver to draw this power to boost acceleration out of corners or for overtaking. In short: he who brakes, wins.

It is a principle that the 911 GT3 R Hybrid brought to the front of the field at the Nürburgring in 2010, where it remained until the 23rd hour. Engine failure may have forced it to retire from this particular race, but this was not the end. The 911 GT3 R Hybrid since went on to compete in a number of major endurance trials around the world. In Zhuhai in the same year, it was recognised as the fastest and most economical GT vehicle in the field.

We don't need to win to make progress. The idea alone motivates us to achieve greater things. Intelligent Performance.



GT-Sport.

GT cars are pure-bred racing cars. They must be based on road-registered sportscars and modifications are restricted to specific areas.

In the early 1990s, Porsche was the driving force behind the renaissance of international GT motorsport. In the meantime, Porsche has established successful cooperation with customer teams. Porsche supplies the race-ready

cars and supports private teams with further development, technical services and the provision of factory drivers.

Whether it's in the Le Mans 24 Hours, the ALMS, the International GT Open or at

national GT championships, Porsche private teams are regular race and championship winners.



Porsche GT-Sport

Porsche one-make championships.

Porsche racing drivers are able to indulge their passion for motorsport in 20 Porsche one-make championships on 5 continents. The philosophy is one of equal opportunities and fairness through

the use of technically identical racing cars. The result is fiercely contested sprints of the highest standard. Based directly on the 911 GT3 RS, 911 GT3 Cup cars compete in races as part of high-level racing events.

At each Porsche one-make championship, Porsche supplies the cars to private teams in race-ready condition and organises the race series and provides support for the drivers, teams and sponsors from its trackside position.

Porsche Mobil 1 Supercup.

The Porsche Mobil 1 Supercup is the world's fastest international one-make race series. With 11 races in total and an average spectatorship of over 100,000, it is held as part of the supporting programme of the FIA Formula One World Championship.



Porsche Mobil 1 Supercup

Porsche Carrera Cup Germany.

The Porsche Carrera Cup Germany is one of the fastest national one-make championships in the world. As a partner series to the DTM (German Touring Car Masters) – the most prominent touring car series in Germany – it offers an abundance of motorsport thrills and an extremely attractive programme of events.

For further information, please visit www.porsche.com/motorsport.

Porsche Sport Driving School.

At Porsche, we are working not only on the evolution of the sports car, but also on the development of the drivers. Safe driving on the road may be second nature, but what about mastering control of a sports car at the limits of sporty

performance? We will help you to perfect your driving safety as well as your advanced skills and techniques step by step.

Under the supervision of our experienced Porsche instructors in your own car or in one provided by the Porsche Sport

Driving School, you can refine your ability on-road or off-road, on international racetracks or on ice or snow. We will be by your side from the start and, if it is your aim, we will accompany you through every training level on the way to obtaining your motorsport licence.

To find out more, please call +49 (0)711 911-78683 or go to www.porsche.de/sportdrivingschool.



Porsche Sport Driving School

Porsche Sports Cup.

In 2011, the Porsche Sports Cup began its seventh season. Six events on five racetracks, including the Nürburgring, Hockenheimring and Spa-Francorchamps, deliver exhilarating excitement. Various types of race are open for entry. From

regularity rallies to sprints, you can compete in the Porsche Sports Cup by bringing your own road-approved Porsche or a Porsche that has been race-modified.

To find out more, please call +49 (0)711 911-12384 or go to www.porschescup.de.



Porsche Sports Cup

Porsche Club Sport.

Porsche Clubs organise a variety of one-off competitions or full series in which drivers compete in various classes. Founded in 1952, today there are 620 clubs in 68 countries with a total membership of approximately 180,000

and the numbers keep growing. The Porsche Club Organisation is one of the largest and longest established automotive associations in the world.

For further information, please call +49 (0)711 911-78307 or go to www.porsche.com.

**Since 1963, we've defined the 911 in terms of sporty performance.
And we've scrutinised it daily for its efficiency-enhancing potential.**

Porsche and the environment.

We've already spoken about our contribution to motorsport. To be more precise, about our responsibility for the future of motorsport. We meet this responsibility with intelligent technology, unconventional ideas and optimum performance.

Our approach to environmental protection is no different. In an era of intensifying debate about global climate change and CO₂ emissions, every automotive manufacturer is asking what it has to offer right now. Our answer has long been the same: maximum efficiency.

Porsche has managed to reduce fuel consumption across all model ranges by a double-digit percentage compared with the respective previous model even though performance has been increased. This is made possible by an efficient drive concept (e.g. DFI and VarioCam Plus), lightweight construction, optimised aerodynamics and low rolling resistance.

The environmental management team at the Porsche Development Centre in Weissach aims to demonstrate a high level of environmental responsibility.

Here, technological developments are carried out with environmental protection in mind. The goal is to enhance performance – but not at the expense of the environment. We achieve this goal with Intelligent Performance, as epitomised by the 911.





Exhaust emission control.

Vehicles manufactured by Porsche demonstrate that even high-performance sports cars can achieve moderate fuel consumption and exhaust emission values in their respective category.

This is achieved, on the one hand, through the use of fuel-efficient technologies such as auto start/stop, thermal management, electrical system recuperation, direct fuel injection, coasting mode and VarioCam Plus.

On the other hand, newly developed catalytic converters provide efficient emission control.

The stereo Lambda control circuitry controls and monitors each cylinder bank separately. For each exhaust tract, oxygen sensors regulate the composition of the exhaust gas, while another Lambda sensor on each cylinder bank monitors

pollutant conversion in the respective catalytic converter.¹⁾

Fuel economy and recycling.

Intelligent lightweight construction has been fundamental to the Porsche identity since 1948, for both economic and ecological reasons. This forms the basis for achieving low fuel consumption values in conjunction with outstanding performance.

It is economical thanks to the high proportion of aluminium, magnesium, plastics and super-high-strength sheet steel used. This is substantially more stable and lighter than conventional steel.

It is also ecological because all materials used are meticulously selected. We use only innovative and environmentally friendly components. All lightweight materials are easily recyclable and each material is

labelled to facilitate its separation for recycling. The reduction in the number of plastic variants helps to ensure more efficient recycling. Recycled plastics are used where they meet our exacting technical requirements.

In short, the new 911 is up to around 95% recyclable.

In addition, Porsche for the most part uses environmentally friendly water-based paints. For us, environmental protection does not begin at the end of a vehicle's life. It starts at the planning and development stage.

Fuel.

All Porsche models – including the new 911 – are already designed to operate on fuels with an ethanol content of up to 10%, e.g. 'E10'. Ethanol has a positive impact on the CO₂ balance since the plants grown for the production of this biofuel also absorb CO₂ from the atmosphere.

The release of hydrocarbons from the fuel system has been minimised thanks in no small part to the active carbon filter and the multilayered material from which the fuel tank is made. All fuel lines are made from multilayered plastic, steel or aluminium.

¹⁾ Not in markets with leaded fuel.



subtle **direct** determined genuine
Personality
perfectionist **clear** mature
nonconformist

SVM 991

**To stand out from the crowd,
you need to express individuality.**

Personalisation options.

The standard specification of the new 911 Carrera models may be second to none, but Porsche still gives you the opportunity to customise your car to your own taste and to give it the personality needed to make it unmistakable.

A variety of customisation options is available for both the exterior and the interior. We appreciate that nobody knows better than you how you wish to express your identity.

You will find more detailed information on the following pages and in the separate price list.

These are not the only ways to style your 911 to your personal preference. How about the personalisation of your car at the factory through Porsche Exclusive, or why not consider our range of aftermarket accessories from Porsche Tequipment? You will find plenty of inspiring ideas in all the relevant

catalogues and your Porsche Centre will be happy to advise you.

There are many ways to explore your own direction. The Porsche identity will never be given an order number, but there is a number by which it will forever be epitomised: 911.



Solid exterior colours.

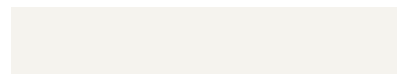

Carrara White



Racing Yellow



Guards Red



Black



Metallic exterior colours.

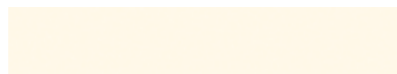

Platinum Silver Metallic



Aqua Blue Metallic



Dark Blue Metallic



Ruby Red Metallic



Anthracite Brown Metallic

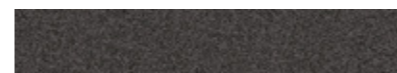

Agate Grey Metallic



Basalt Black Metallic



Special exterior colours.

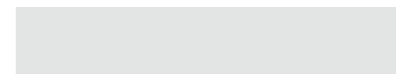

GT Silver Metallic

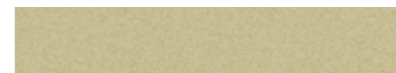

Lime Gold Metallic



Cognac Metallic



Standard interior colours.
**Leatherette/leather¹⁾/
 soft-touch paint²⁾
 interior colour.**

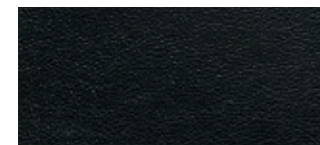

Black

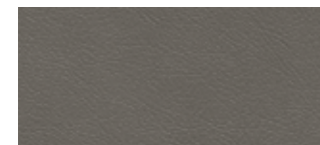

Platinum Grey

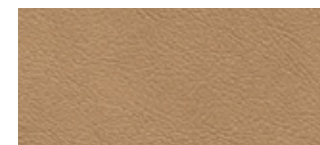

Luxor Beige



Yachting Blue

Carpet.



Black

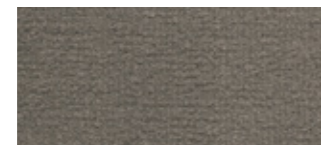

Platinum Grey



Luxor Beige



Yachting Blue

Rooflining.³⁾

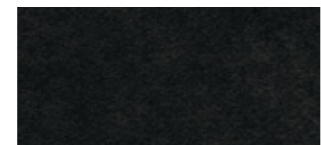

Black

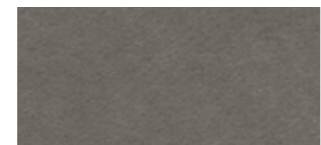

Platinum Grey



Luxor Beige

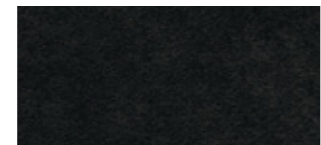

Black

**Special colours and
 two-tone combination interior.¹⁾
 Leather/soft-touch paint²⁾
 in interior colour.**

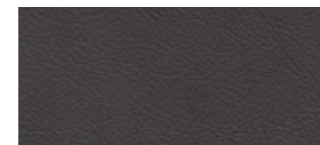

Agate Grey

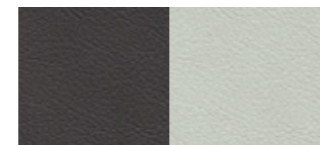

Agate Grey and Pebble Grey

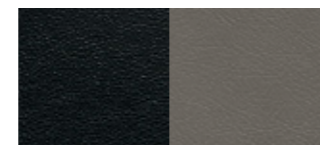

Black and Platinum Grey

Carpet.



Agate Grey



Pebble Grey

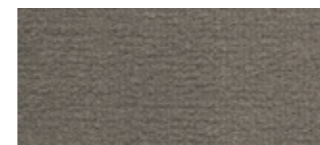

Platinum Grey

Natural leather interior.¹⁾

**Leather/soft-touch paint
 in interior colour.**



Espresso

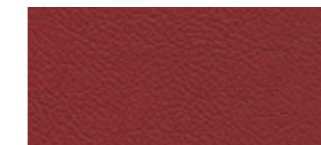

Carrera Red⁴⁾



Black

Carpet.

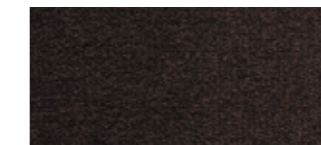

Espresso

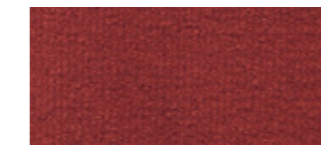

Carrera Red

Rooflining.³⁾

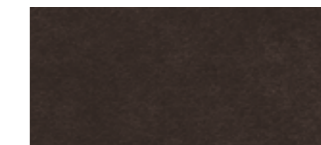

Espresso

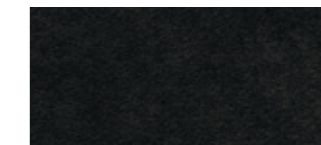

Black

Rooflining.³⁾

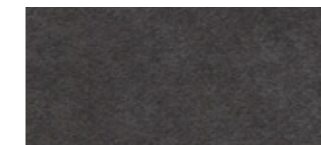

Agate Grey

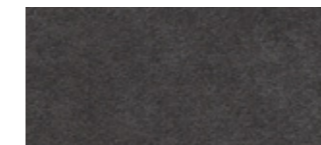

Agate Grey

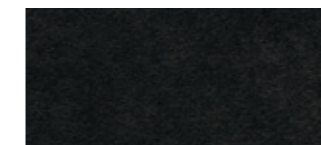

Black

See separate price list for recommended colour combinations.

¹⁾ Leather finish on dashboard upper section including instrument shroud, front section of dashboard including front passenger airbag cover, steering wheel rim and airbag module, door upper panels, upper section of rear side panels, seat centres, seat bolsters, headrests, back of front seat backrests, front seat bases, door centre panels, centre console side sections, transmission tunnel, rear compartment.

²⁾ Soft-touch paint in interior colour; sun visors and inner door sill guards with film finish in interior colour.

³⁾ Rooflining in Alcantara.

⁴⁾ Soft-touch paint in interior colour, sun visors and inner door sill guards with black film finish.



Trim strips in a high-gloss finish



Rear wiper

Product	911 Carrera	911 Carrera S	I no.	Page
Exterior.				
Metallic paint	○	○	Code	104
Special colours	○	○	Code	106
Colours to sample	○	○	Code	
Porsche Dynamic Light System (PDLS)	○	○	603	65
Rear wiper	○	○	425	108
Windscreen with grey top-tint	○	○	567	
Automatically dimming mirrors with integrated rain sensor	○	○	P13	76
Slide/tilt sunroof	○	○	651	76
Deletion of model designation	A	A	498	
ParkAssist (rear)	○	○	635	75
ParkAssist (front and rear)	○	○	636	75
Roof transport system	○	○	549	77
Porsche Entry & Drive	○	○	625	78
Electrically folding exterior mirrors including courtesy lighting	○	○	748	76
'911' badge	○	○	911	15
Trim strips in a high-gloss finish	○	○	559	108

The vehicles illustrated in the chapter on personalisation may include additional options not featured in this catalogue. For information on these options, please consult your Porsche Centre. For more information on the options featured in this catalogue, please refer to the separate price list.

Product	911 Carrera	911 Carrera S	I no.	Page
Engine, transmission and chassis.				
Porsche Doppelkupplung (PDK, 7-speed)	○	○	250	38
Porsche Ceramic Composite Brake (PCCB)	○	○	450	60
Porsche Active Suspension Management (PASM)	○	●	475	44
Porsche Torque Vectoring (PTV) with mechanically locking rear differential in conjunction with manual gearbox	○	●	220	54
Porsche Torque Vectoring Plus (PTV Plus) with electronically locking rear differential in conjunction with optional PDK	○	●	221	54
Sport Chrono Package	○	○	639/640	49
Porsche Dynamic Chassis Control (PDCC)	–	○	031/352	46
PASM sports suspension (20 mm lower) only in conjunction with PTV/PTV Plus and 20-inch wheels	○	○	030	45
Sports exhaust system	○	○	176	49
Power steering Plus	○	○	658	48
Wheels.				
20-inch Carrera S wheels	○	●	423	52
20-inch SportDesign wheels	○	○	428	109
20-inch Carrera Classic wheels	○	○	427	109
Wheel centres with full-colour Porsche Crest	○	○	446	
Tyre Pressure Monitoring (TPM)	○	○	482	53

– not available ○ I number/extra-cost option ● standard equipment A available at no extra cost



Porsche Ceramic Composite Brake (PCCB)



20-inch Carrera Classic wheel



20-inch SportDesign wheel



Sports seat



Fully electric Sports seat



Sports seat Plus



Adaptive Sports seat Plus

Product	911 Carrera		I no.	Page
	911 Carrera	911 Carrera S		
Interior.				
Light design package	○	○	630	75
HomeLink® (programmable garage door opener)	○	○	608	74
Preparation for Porsche Vehicle Tracking System (PVTs)	○	○	674	78
Cruise control	○	○	454	74
Sports seats	●	●	–	72
Fully electric Sports seats (14-way) with memory package including electric steering column adjustment	○	○	P06	72
Sports seats Plus	○	○	P05	72
Adaptive Sports seats Plus (18-way) with memory package including steering column adjustment	○	○	P07	72
Seat heating	○	○	342	73
Steering wheel heating (only in conjunction with seat heating)	○	○	345	71
Seat ventilation (only in conjunction with seat heating)	○	○	541	73
ISOFIX child seat preparation for front passenger seat	○	○	899	73
Fire extinguisher	○	○	509	
Rev counter dial face in black	●	A	022	
Floor mats	○	○	810	

– not available ○ I number/extra-cost option ● standard equipment A available at no extra cost

Product	911 Carrera		I no.	Page
	911 Carrera	911 Carrera S		
Interior: leather.				
Multifunction steering wheel	○	○	844	70
Leather seats	○	○	983	
Leather interior package in standard colour	○	○	981	106
Leather interior package in special colour	○	○	798	106
Leather interior package in two-tone combination	○	○	970	106
Leather interior package in natural leather	○	○	998	107
Leather interior in colour to sample	○	○	799	
Audio and communication options for vehicles with CDR-31 audio system.				
Mobile phone preparation ^{1),2)}	○	○	619	82
BOSE® Surround Sound System	○	○	680	84
Burmester® High-End Surround Sound System	○	○	682	86
Six-disc CD autochanger ³⁾	○	○	692	80

¹⁾ For information on compatible mobile phones, please visit www.porsche.com or contact your Porsche Centre.

²⁾ Mobile phone preparation or telephone module in HFP mode: The use of a mobile phone inside a car may cause an increase in the interior electromagnetic field strength and, accordingly, in the electromagnetic radiation to which passengers are exposed. If a cradle is used to mount the mobile phone, the field strength in the passenger compartment can be reduced because the phone can be connected up to the external aerial (feature depends on how specific mobile phones connect to the cradle). For information about the availability of a cradle for your mobile phone, please contact your Porsche Centre. The use of the telephone module for PCM via Bluetooth® SAP connection or with inserted SIM card prevents exposure to electromagnetic radiation as only the car's external aerial is ever used.

³⁾ May be incompatible with some copy-protected CDs.



Leather interior package in Luxor Beige



Leather interior package in two-tone combination of Black and Platinum Grey



BOSE® Surround Sound System



Burmester® High-End Surround Sound System

Product	911 Carrera		I no.	Page
	911 Carrera	911 Carrera S		
Audio and communication options for vehicles with PCM.				
Porsche Communication Management (PCM) including navigation module ¹⁾	o	o	P23	80
Electronic logbook	o	o	641	80
Voice control system	o	o	671	80
TV tuner ²⁾	o	o	676	82
Telephone module with cordless handset ^{3),4)}	o	o	669	82
Mobile phone preparation ^{3),4)}	o	o	619	82
BOSE® Surround Sound System	o	o	680	84
Burmester® High-End Surround Sound System	o	o	682	86
Six-disc CD/DVD autochanger ¹⁾	o	o	693	80

¹⁾ May be incompatible with some copy-protected CDs.

²⁾ For receiving analogue and digital TV signals (DVB-T) (where available).

³⁾ For information on compatible mobile phones, please visit www.porsche.com or contact your Porsche Centre.

⁴⁾ Mobile phone preparation or telephone module in HFP mode: The use of a mobile phone inside a car may cause an increase in the interior electromagnetic field strength and, accordingly, in the electromagnetic radiation to which passengers are exposed. If a cradle is used to mount the mobile phone, the field strength in the passenger compartment can be reduced because the phone can be connected up to the external aerial (feature depends on how specific mobile phones connect to the cradle). For information about the availability of a cradle for your mobile phone, please contact your Porsche Centre. The use of the telephone module for PCM via Bluetooth® SAP connection or with inserted SIM card prevents exposure to electromagnetic radiation as only the car's external aerial is ever used.



Porsche Exclusive

A distinctive identity is another form of exclusivity.

With the range of options featured in this catalogue, you can make your Porsche even more special. Introducing Porsche Exclusive. Have your vehicle individually and exclusively tailored to your wishes

even before it leaves the factory. Aesthetically and technically, inside and outside, using fine materials and with customary Porsche quality.

Our overriding principle? That your car is uniquely handcrafted to your taste. You will find a wide range of design

options in the separate Porsche Exclusive 911 catalogue.

Either your Porsche Centre or the customer centre in Zuffenhausen (tel. +49 (0)711 911-25332) will be happy to answer any questions about Porsche Exclusive that you may have.

Please note that delivery times may be extended for certain Porsche Exclusive equipment.

Porsche Car Configurator

Create your own identity.

Taste, personality, style. You decide how to refine the new 911 Carrera to your personal preference. With the Porsche Car Configurator, you can see the result instantly on your computer. Just five steps are all it takes to create the Porsche of your dreams.

To access the Porsche Car Configurator, please visit www.porsche.com.

Willkommen im Porsche Car Configurator.
Wählen Sie Ihr favorisiertes Modell.

Boxster Cayman

911 Panamera Cayenne

Alle erhältlichen Porsche Modelle in der Übersicht ▶

Der neue 911
Ab sofort im Porsche Car Configurator verfügbar. Wählen Sie Modell, Farbe, Ausstattung nach Ihren Wünschen im 2D oder 3D Modus.
▶ Jetzt Entdecken

▶ Mein Modell laden

▶ Modellvergleich

Factory collection

The first time that you drive your new Porsche will be a truly special moment. Nevertheless, you can make it even more special with Porsche factory collection. Come and collect your Porsche in Stuttgart-Zuffenhausen or Leipzig and be the one to take it to its rightful place: on the road.

Before this, we invite you behind the scenes of the Porsche production process. As part of a guided factory tour, you will see how much passion

and precision goes into everything we do. You can then take time to reflect on your experience over a leisurely lunch and look forward to the high point of the day: taking delivery of your Porsche. Our specialists will take their time to explain everything about your new car in as much detail as you wish.

That leaves you with just one more thing to decide: from which factory to collect your Porsche? Stuttgart-Zuffenhausen is steeped in tradition

and history. Here, you can visit the Porsche Museum to experience and learn about every aspect of the Porsche marque, with legendary models from a sportscar history spanning over 60 years.

Or, if you would prefer your factory collection to be a little more on the sporty side, visit our production location in Leipzig. Your first driving experience will be a test drive in a Porsche model identical to the one you purchased and under the expert supervision of one

of our instructors. Hone your skills on-road on the FIA-certified test circuit or off-road in a Cayenne on our off-road track.

If you do opt for the factory collection, please contact your Porsche Centre to arrange a collection date. We will be happy to assist in the planning of your trip. You will also be given information on the formalities, legal or otherwise, to be completed before you can take delivery.



Panorama



Porsche Centres

Your Porsche Centre can assist you with every aspect of purchasing and owning your Porsche. You will also find a wide range of products and services, including genuine Porsche parts and accessories.



Porsche Assistance

Enjoy peace of mind with our exclusive breakdown and accident recovery service. Membership is free when you buy a new Porsche.



Porsche Financial Services

Our range of financial services is innovative and specially tailored to the needs of Porsche owners. Products range from attractive finance and leasing options to vehicle insurance and the Porsche Card.



Porsche Exclusive

Realise your vision of the perfect Porsche with our factory customisation programme. From styling enhancements to performance upgrades, all modifications are uniquely handcrafted for your Porsche.



Porsche Tequipment

Personalise your Porsche at any time after purchase with the Tequipment range of approved accessories. Perfectly matched to your vehicle and covered in full by your original vehicle warranty.



Porsche Design Driver's Selection

With products ranging from fashion and accessories to tailored luggage, this unique collection combines quality and style with everyday practicality.



Porsche Online

For all the latest news and information from Porsche, go to www.porsche.com.

Porsche Approved Programme

So that our vehicles remain reliable and retain their value, we guarantee that all our Porsche Approved cars meet the most stringent Porsche quality standards, anywhere in the world. Every car is backed by the Porsche Approved warranty.



Porsche Classic

Your specialist source for genuine Porsche parts and technical documentation as well as servicing, repair and restoration for all types of classic Porsche. Find out more at www.porsche.com/classic.



Christophorus

Our bi-monthly magazine for Porsche owners has news, interviews and a wide variety of features from throughout the world of Porsche.



Porsche Driving Experience

1. Porsche Travel Club.

Exclusive driving holidays and incentive ideas combining luxury and adventure, worldwide. To find out more, call +49 (0)711 911-78155. E-mail: info@porschetravelclub.de



2. Porsche Sport Driving School

Develop your skill and explore your Porsche with the Porsche Sport Driving School. To learn about events at some of the world's most famous racing venues, call +49 (0)711 911-78683. E-mail: sportdrivingschool@porsche.de



Porsche Clubs

Since the first Porsche Club was founded in 1952, their number has grown to 620 with a total of 180,000 members worldwide. To find out more, call +49 (0)711 911-78307 or go to www.porsche.com.



Porsche Museum

More than 80 vehicles are waiting to take you back through every stage of Porsche history. They include such icons as the 356, 911 and 917 and many other special exhibits presented in an atmosphere you can't experience anywhere else.



You can obtain the latest brochures for Porsche Exclusive, Porsche Tequipment, Porsche Design Driver's Selection and Porsche Driving Experience from your Porsche Centre.

visionary traditional formal
911 identity
functional practical agile fascinating
Dr. Ing.



Technical data.

	911 Carrera	911 Carrera S
Engine		
Cylinders	6	6
Displacement	3,436 cm ³	3,800 cm ³
Max. power (DIN) at rpm	257 kW (350 hp) 7,400	294 kW (400 hp) 7,400
Max. torque at rpm	390 Nm 5,600	440 Nm 5,600
Compression ratio	12.5:1	12.5:1
Transmission		
Layout	Rear-wheel drive	Rear-wheel drive
Manual gearbox	7-speed	7-speed
PDK (optional)	7-speed	7-speed
Chassis		
Front axle	McPherson strut suspension	McPherson strut suspension
Rear axle	LSA multi-link suspension	LSA multi-link suspension
Steering	Variable steering ratio, power-assisted (electromechanical)	Variable steering ratio, power-assisted (electromechanical)
Turning circle	11.1 m	11.1 m
Brakes	Four-piston aluminium monobloc fixed calipers front and rear, discs internally vented and cross-drilled	Six-piston aluminium monobloc fixed calipers at front, four-piston aluminium monobloc fixed calipers at rear, discs internally vented and cross-drilled
Vehicle stability system	Enhanced PSM (with ABS 8.0)	Enhanced PSM (with ABS 8.0)
Anti-lock braking system	ABS 8.0	ABS 8.0
Standard wheels	Front: 8.5 J x 19 ET 54, Rear: 11 J x 19 ET 69	Front: 8.5 J x 20 ET 51, Rear: 11 J x 20 ET 70
Standard tyres	Front: 235/40 ZR 19, Rear: 285/35 ZR 19	Front: 245/35 ZR 20, Rear: 295/30 ZR 20

	911 Carrera Manual/PDK	911 Carrera S Manual/PDK
Weights		
Unladen (DIN)	1,380 kg/1,400 kg	1,395 kg/1,415 kg
Unladen (EC) ¹⁾	1,455 kg/1,475 kg	1,470 kg/1,490 kg
Permissible gross weight	1,795 kg/1,815 kg	1,830 kg/1,850 kg
Performance	Manual/PDK	Manual/PDK
Top speed	289 km/h/287 km/h	304 km/h/302 km/h
0–100 km/h	4.8 secs/4.6 secs	4.5 secs/4.3 secs
Sport Chrono Package (with PDK) 0–100 km/h	–/4.4 secs	–/4.1 secs
0–160 km/h	10.4 secs/10.0 secs	9.4 secs/9.0 secs
Sport Chrono Package (with PDK) 0–160 km/h	–/9.7 secs	–/8.7 secs
Flexibility (80–120 km/h) in 5th gear	6.4 secs/–	5.9 secs/–
Overtaking acceleration (80–120 km)	–/2.8 secs	–/2.4 secs
Fuel consumption/emissions²⁾	Manual/PDK	Manual/PDK
Urban in l/100 km	12.8/11.2	13.8/12.2
Extra urban in l/100 km	6.8/6.5	7.1/6.7
Combined in l/100 km	9.0/8.2	9.5/8.7
CO ₂ emissions g/km	212/194	224/205
Dimensions/aerodynamics		
Length	4,491 mm	4,491 mm
Width	1,808 mm	1,808 mm
Height	1,303 mm	1,295 mm
Wheelbase	2,450 mm	2,450 mm
Luggage compartment volume (German Car Manufacturers' Assoc.)	135 litres	135 litres
Tank capacity (refill volume)	64 litres	64 litres
Drag coefficient	0.29	0.29

¹⁾ Weight is calculated in accordance with the relevant EC Directives and is valid for vehicles with standard specification only. Optional equipment increases this figure. The figure given includes 68 kg for the driver and 7 kg for luggage.
²⁾ Data determined in the NEDC (New European Driving Cycle) in accordance with the Euro 5 (715/2007/EC and 692/2008/EC) measurement method. The figures do not refer to an individual vehicle nor do they constitute part of the offer. They are intended solely as a means of comparing different types of vehicle. You can obtain further information about individual vehicles from your Porsche Centre. Fuel consumption calculated for vehicles with standard specification only. A vehicle's fuel consumption and CO₂ emissions depend not only on its efficient use of fuel but also on driving style and other non-technical factors. Actual consumption and performance may vary with items of optional equipment.

Index

#	Climate control	74	F	L	Parking brake, electric	62	Power steering	48	Sport Chrono Package	49	V	
'911' badge	Coasting	39	Factory collection	115	Leather	111	Power steering Plus	48	SPORT PLUS button	50	VarioCam Plus system	32
A	Colours		Front axle	43	Light design package	75	Personalisation	102	Sports exhaust system	34, 49	Voice control system	80
Airbags	Exterior	104	Fuel	99	Lights	64	Porsche Active Suspension Management (PASM)	44	Sports suspension	45	W	
Anti-theft protection	Interior	106	Fuel consumption	99	Logbook, electronic	80	Porsche Ceramic Composite Brake (PCCB)	60	Steering	48	'Welcome Home' lighting	74
Audio interface, universal	Comfort	66	Fuel system	99	Luggage compartment	77	Porsche Communication Management (PCM)	80	Steering wheel heating	71	Wheels	52
AudioPilot®	Communication	79	H	M	Headlight cleaning system	64	Porsche Doppelkupplung (PDK)	38	Steering wheels			
Auto start/stop function	Cruise control	74	HomeLink®	36	Manual gearbox	36	Porsche Dynamic Chassis Control (PDCC)	46	Multifunction steering wheel	70		
B	Direct fuel injection (DFI)	32	(programmable garage door opener)	74	Materials	99	Porsche Dynamic Light System (PDLS)	65	SportDesign steering wheel	71		
Bi-Xenon headlights	Dry-sump lubrication, integrated	34	I	O	Memory package	72	Porsche Entry & Drive Protection System (POSIP)	63	Sports steering wheel	70		
Body	Dynamic engine mounts	51	l numbers	108	Mobile phone preparation	82	Porsche Side Impact Protection System (POSIP)	63	Stereo Lambda control circuits	99		
BOSE® Surround Sound System			K	P	Models	8	Porsche Stability Management (PSM)	53	T			
Brakes	Electrical system recuperation	31	Instruments	69	Motorsport	90	Porsche Torque Vectoring (PTV)	54	Technical data	120		
Burmester®	Emission control	99	Intake manifold	34	On-board computer	69	Porsche Torque Vectoring Plus (PTV Plus)	54	Telephone module	82		
High-End Surround Sound System	Engine management, electronic	35	K	P	On-board diagnostics	35	Porsche Vehicle Tracking System (PVTS)	78	TFT display	69		
C	Engineered safety design	42	Knock control, cylinder-specific	35	On-board diagnostics	35	Porsche Vehicle Tracking System (PVTS)	78	Thermal management	31		
Catalytic converter	Engines	26	P	P	On-board diagnostics	35	Panorama	116	Transmission	36		
CD/DVD autochanger	3.4-litre boxer engine	28	Panorama	116	On-board diagnostics	35	ParkAssist	75	Trim strip in a high-gloss finish	108		
CDR-31 audio system	3.8-litre boxer engine	28	ParkAssist	75	On-board diagnostics	35			TV tuner	82		
Chassis	Environment	96			On-board diagnostics	35			Tyre Pressure Monitoring (TPM)	53		
	Exhaust system	34			On-board diagnostics	35						
	Exterior mirrors and rear-view mirror	76			On-board diagnostics	35						

The models featured in this publication are approved for road use in Germany. Some items of equipment are available as extra-cost options only. The availability of models and options may vary from market to market due to local restrictions and regulations. For information on standard and optional equipment, please consult your Porsche Centre. All information regarding construction, features, design, performance, dimensions, weight, fuel consumption and running costs is correct to the best of our knowledge at the time of going to print. Porsche reserves the right to alter specifications, equipment and delivery scopes without prior notice. Colours may differ from those illustrated. Errors and omissions excepted.

© Dr. Ing. h.c. F. Porsche AG, 2011
All text, illustrations and other information in this publication are subject to the copyright of Dr. Ing. h.c. F. Porsche AG.

Any reproduction, duplication or other use is prohibited without the prior written consent of Dr. Ing. h.c. F. Porsche AG.

Dr. Ing. h.c. F. Porsche AG supports the use of paper from sustainable forests. This catalogue is printed on paper made from 100% PEFC-certified pulp (Programme for the Endorsement of Forest Certification).

Porsche, the Porsche Crest, 911, Carrera, Boxster, Cayman, Cayenne, Panamera, Targa, PCCB, PCM, PSM, Tequipment, Tiptronic and other marks are registered trademarks of Dr. Ing. h.c. F. Porsche AG.

Dr. Ing. h.c. F. Porsche AG
Porscheplatz 1
70435 Stuttgart
Germany
www.porsche.com

Edition: 05/11
Printed in Germany
WSLC1201000220 GB/WW

