



Our eyes are always on the road ahead. Striving to find ways to help you be safe. Go farther on a tank of gas. To help the earth go further on its limited resources. Moving Forward is embedded in our DNA. It's shared by our dealers, and ultimately inspired by our customers. toyota.com 1-800-GO-TOYOTA



VENZA



AVALON



CAMRY



CAMRY SOLARA



PRIUS



COROLLA



YARIS



MATRIX



TUNDRA



CAMRY HYBRID



TACOMA



LAND CRUISER



4RUNNER



RAV4



HIGHLANDER HYBRID



FJ CRUISER



SEQUOIA

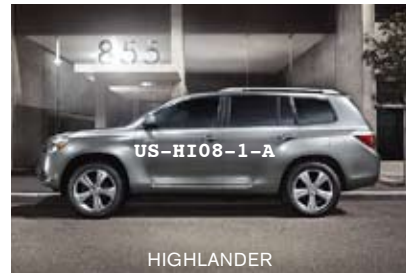

HIGHLANDER



SIENNA



Hybrid Synergy Drive,[®] powering the Prius, Camry Hybrid and Highlander Hybrid, combines a clean-burning gas engine with an efficient electric motor to deliver excellent fuel economy, low emissions and performance.

CAMRY 10



US-CY10-1-A

FOCUS ON SUSTAINABILITY This brochure is printed on Sappi's Opus Gloss environmentally responsible paper. 100% of the electricity used to manufacture this paper has been generated from certified renewable energy sources. Opus Gloss uses 30% post-consumer recovered fiber and is FSC (Forest Stewardship Council) certified. This certification assures that this brochure was printed on paper from well-managed forests following FSC requirements through the entire chain of custody - from the tree, to the printer, to the consumer. It is one of the most environmentally responsible coated papers available today.

Toyota's core printing partners embrace responsible forestry management through either FSC or SFI certifications. These printers practice recycling policies for hazardous and non-hazardous materials and print with inks that reduce volatile organic compound (VOC) emissions into the atmosphere. Additionally, one of Toyota's print partners uses renewable wind energy for 100% of its electricity needs, while another generates all its own electrical power and is the only Air Quality Management District (AQMD) certified, "totally enclosed" commercial printing facility in the U.S. with virtually zero VOC emissions.

Quality. Dependability. And Reliability. These have been the cornerstones of Camry since the beginning. Yet every year, Camry gets a bit more refined. Its dependability is that much more confidence-inspiring. And its reliability rewards Camry owners with a deeper sense of satisfaction. You see, our engineers never rest. No wonder Camry continues to be, year after year, the number-one-selling car in America! The 2010 Toyota Camry. Moving Forward.



Hybrid shown in Blue Whisper Mica with available Upgrade Package and fog lamps; XLE shown in Blue Ribbon Metallic with available Smart Key System²

If you're going to get what you want out of life, why not get exactly what you desire? Some people are happy to be practical. Some crave performance. And others want the benefits of our hybrid technology. So go ahead: select the Camry model – Camry, LE, SE, XLE or Hybrid – that works for you.

For 2010, the look of Camry takes a step forward. Along with resculpting the front bumper and headlights, our designers gave each 2010 Camry model its own distinct grille. Even Camry Hybrid gets a fresh face all its own. So, no matter which Camry you drive, you can express your unique sense of style.

With the 2010 Camry SE, the focus is on driving performance. Your first hint is under the rear bumper: the chrome-tipped dual exhaust. Under the hood, the hints get even bigger. An available 3.5-liter dual VVT-i V6 develops a whopping 268 horsepower at 6200 rpm. Power from the SE's standard 2.5-liter DOHC 16-valve 4-cylinder engine is increased to 179 hp. And thanks to dual VVT-i – that's short for Variable Valve Timing with intelligence – the power from these engines is delivered with remarkable efficiency. VVT-i adjusts the timing of the valves independently to ensure an optimum balance of power and precision.

US-CY10-3-A



SE shown in Magnetic Gray Metallic with available Smart Key System¹ and color-keyed rear lip spoiler.

US-CY10-5-A



CAMRY SE

Camry SE expresses itself with a mesh grille, color-keyed front and rear underbody spoilers and side rocker panel moldings. A rear deck lid spoiler is available. And for 2010, Camry SE features a rear combination lamp that utilizes 13 brighter, longer-lasting, energy-efficient LEDs.

1. See footnote 6 in Features section.

Camry XLE sends its message loud and clear: Its striking lines and bold look express the essence of Toyota Camry at its best. For 2010, the available 3.5-liter dual VVT-i V6, along with its 6-speed automatic transmission with sequential shift, generates the kind of smooth, effortless power that makes driving its own reward. And XLE's stylish exterior conceals a spacious interior designed to surround both driver and passengers with a host of advanced features.

US-CY10-6-A



US-CY10-7-A



XLE V6 shown in Spruce Mica with available Smart Key System¹ and DVD navigation system² with integrated backup camera³

CAMRY XLE

Camry XLE has always been outstanding. Now it stands out even more. For 2010, our designers gave Camry XLE a new color-keyed grille with chrome accents, along with a front bumper that fits the fog lamps into a smoothly contoured recess. Together, these design details create a stylish look that's exclusive to the XLE.

US-CY10-8-A



SMART KEY¹

With the available Smart Key System with Push Button Start, Camry can be unlocked and started by having the Smart Key in the driver's pocket or purse. A proximity sensor in the car door and a radio pulse generator in the key housing form the electronic access and authorization system that makes it all work.

1. See footnote 6 in Features section. 2. See footnote 15 in Features section. 3. See footnote 16 in Features section.

Considering all the standard features found on Camry XLE, it would be more appropriate to think “high” standards. Take the XLE's dual zone automatic climate control with Plasmacluster™¹ ionizer, for example. It's just one extraordinary touch that makes Camry XLE such an exceptional sedan. An auxiliary audio jack, wood-grain-style interior trim and HomeLink®² universal transceiver are just a few of the additional features that define an interior that was designed with your total comfort in mind.



US-CY10-11-A

HEATED SEATS

On Camry XLE, heated front seats³ are an available option. At the touch of a button, the driver or front passenger can summon soothing warmth to their seat, quickly taking the chill off.

US-CY07-50-D



US-CY10-10-A

FRAICHIR™ SEATS

The seat covers in Camry Hybrid and XLE are treated with the Fraichir™ process. The fabric is coated with a substance called Sericin, an extract from silkworm cocoons refined to great purity, that is gentle on the skin of those seated in the car.

US-ICY10-1-A

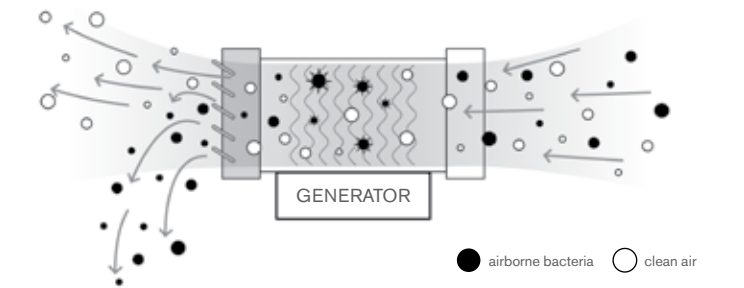

PLASMACLUSTER™

Exclusive to XLE and Hybrid grades, the Plasmacluster™ ionizer helps enhance the air quality inside the cabin. The Plasmacluster™ generates positive ions, which exist in nature and are harmless to humans. As a result, significantly fewer germs are emitted into the air of the cabin.

XLE V6 shown in Bisque leather with available DVD navigation system,³ heated front seats and Smart Key System⁴ with Push Button Start.

1. See footnote 11 in Features section. 2. See footnote 18 in Features section. 3. See footnote 15 in Features section. 4. See footnote 6 in Features section. 5. Requires available leather-trimmed seats. 6. See footnote 7 in Features section.

It just wouldn't be Camry if it didn't offer the latest technologies to enhance your driving experience. On Camry SE, XLE and Hybrid, you can opt for an available voice-activated DVD navigation system.¹ The system integrates XM NavTraffic[®], a technology that comes with the complimentary 90-day subscription to XM Satellite Radio² included when you opt for the DVD navigation system. XM NavTraffic[®] uses real-time traffic reports to help plan your route.

US-CY10-12-A



Available DVD navigation system¹ with XM NavTraffic[®].

BUILT-IN VOICE-ACTIVATED DVD NAVIGATION^{1,3}

If you like the rush of driving Camry SE, or the plush treatment of XLE, the available touch-screen DVD navigation system is your ideal traveling companion. It's voice-activated to make a convenient tool even easier to use.



US-CY10-16-A

MP3-COMPATIBLE CD PLAYER

Toyota understands how you like your music. Even if you lay your tracks down in MP3/WMA formats on CD, the new Camry is fully capable of playing them back, no problem.



US-CY10-18-A

BACKUP CAMERA^{4,5}

The available voice-activated DVD navigation system integrates a backup camera. When backing up, the area behind the vehicle visible to the camera is displayed on the touch-screen of the voice-activated DVD navigation system.

USB PORT

Play your personal music files⁶ with ease. There's an available USB port on the 2010 Camry that's ready and waiting for your flash drive. There's also an auxiliary audio jack.



US-CY10-14-A



US-CY10-15-A



US-CY10-13-A



US-CY10-17-A

XM SATELLITE RADIO²

If you're choosing Camry, you're all about getting things just the way you like them. So why listen to any old broadcast? Available XM Satellite Radio offers 170-plus channels of music, news and sports.

JBL[®] SOUND SYSTEM

An available 8-speaker JBL[®] sound system lets you get your music from many sources. There's AM/FM, of course, and a 6-disc in-dash CD changer. It also has an integrated satellite radio, an auxiliary audio jack, streaming audio via Bluetooth[®] and the new USB port. To make sure it all comes through with deep, rich bass, JBL[®]'s Distributed Subwoofer System (DSS) uses a quartet of 6 x 9-inch woofers.

1. See footnote 15 in Features section. 2. See footnote 12 in Features section. 3. Available on SE with automatic transmission, XLE and Hybrid only. 4. See footnote 16 in Features section. 5. Requires DVD navigation system. Available on SE with automatic transmission, XLE and Hybrid only. 6. May not be compatible with all MP3/WMA players and like models. 7. See footnote 14 in Features section.

Camry XLE is first and foremost about comfort. The available heated seats,¹ or the skin-pampering Fraichir™² fabric and Plasmacluster™³ ionizer attest to that. But that's only the beginning of the XLE comfort story. The front and rear seating zones of XLE (as well as Hybrid) each have their own vents – six upper and four lower – so that passengers in both areas can experience the same exceptional level of comfort.



DUAL ZONE AUTOMATIC CLIMATE CONTROL

Camry XLE makes it easy for everyone inside to sit back and relax in comfort. With its dual zone automatic climate control system, the driver and front passenger can each set their ideal temperature, and the system does the rest. The air conditioning and heating systems are activated as needed to quickly achieve the desired temperature settings. So if the driver likes it 68 degrees while the front passenger prefers 72 degrees, it's no problem.

1. Requires available leather-trimmed seats. 2. See footnote 7 in Features section. 3. See footnote 11 in Features section. 4. See footnote 15 in Features section. 5. See footnote 6 in Features section.



MOONROOF⁶

Keep an eye on the beauty outside day or night through Camry's moonroof, available as a package with a sliding sunshade, dual illuminated visor vanity mirrors and a rear personal reading light.



VERSATILE REAR SEATING

A: Reclining rear seats are standard on Camry XLE. B: A 60/40 split fold-down rear seat offers the capability of carrying long objects safely and securely in Camry and LE. You can take your friends and your shopping trophies with you at the same time.

6. Standard on XLE. Not available on Camry grade.

US-PRS04-11-B



Camry Hybrid. Behind its bold new face, featuring an exclusive new design for the grille, bumper and headlamps, the 2010 Camry Hybrid uses technology called Hybrid Synergy Drive® to place it among the leaders of high fuel efficiency and clean-air consciousness. In fact, Camry Hybrid garners a 34 mpg highway rating¹ and produces 70% fewer smog-forming emissions compared to the average new vehicle. And it does this with all the style and performance, all the reliability and dependability, that Toyota Camry is famous for.

US-CY10-24-A

DID YOU KNOW?

Full hybrid technology, such as Hybrid Synergy Drive®, uses the gasoline engine intermittently, while in Mild hybrids the gasoline engine runs continuously and the electric motor is used only to assist the gasoline engine.



Hybrid shown in Aloe Green Metallic with available Upgrade Package, fog lamps and moonroof.

CAMRY HYBRID INTERIOR

US-CY10-26-A



Hybrid interior shown in Ash with available Upgrade Package with DVD Navigation¹ with XM NavTraffic.*

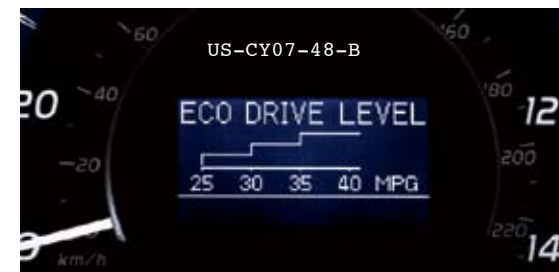

US-CY07-48-B

ECO DRIVE LEVEL DISPLAY

On the ECO Drive Level display, Optitron gauges, specially lighted for easy reading even in daylight, provide current fuel economy information while driving.



US-CY07-75-A

ECO COOL

During heating and cooling, limiting the number of times the engine starts or the electric compressor runs helps reduce emissions and power consumption while improving fuel economy.

¹. See footnote 15 in Features section.

ENERGY MONITOR

The available multi-information display keeps you continuously apprised of Hybrid Synergy Drive's flow of energy and its management.



POWER CONTROL UNIT

Part of Hybrid Synergy Drive's Power Control Unit is an inverter that transforms direct current supplied by the battery to alternating current used by the system to turn the electric motor and for use in the generator.

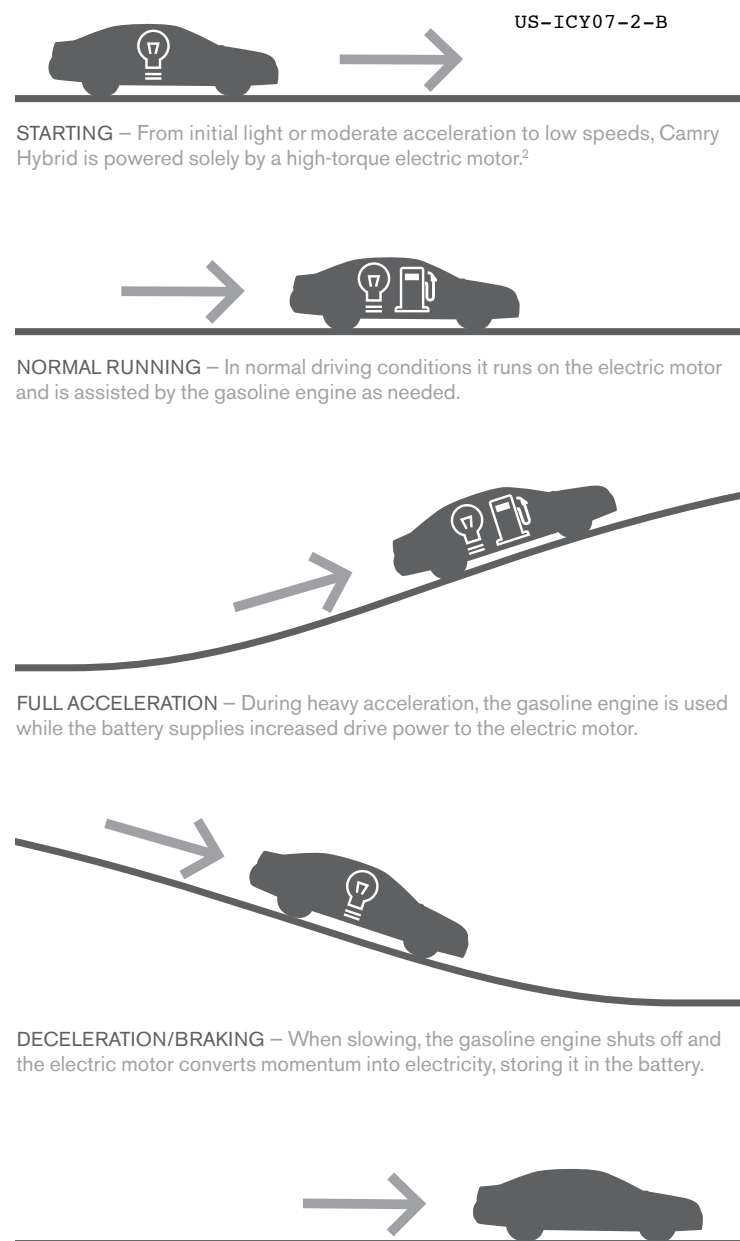

STOPPING – When Camry Hybrid comes to a stop, its gasoline engine shuts off to conserve fuel and reduce emissions.³

1. 2009 EPA-estimated mileage. Actual mileage will vary. 2. Gasoline engine utilized for acceleration on cold starts and full acceleration. 3. The preceding is based on a "likely scenario" for optimal driving conditions.

For 2010, Camry offers a new 2.5-liter 4-cylinder engine that uses technology called Variable Valve Timing with intelligence (VVT-i) to bring more power to the party – up to 179 hp in the Camry SE. Yet with its new, more powerful 4-cylinder engine, Camry still gets an EPA-estimated 22 city/33 highway mpg rating.¹ The available 3.5-liter V6 also applies VVT-i to help increase the power and torque placed at your disposal. Combined with the 6-speed automatic transmission with sequential shift, it takes the experience of driving Camry to new levels of driving pleasure.

4-CYLINDER ENGINE AND VVT-i

The 4-cylinder in this year's Camry is a new 2.5-liter 169-hp DOHC 16-valve engine with dual Variable Valve Timing with intelligence (VVT-i) that gives you the responsive performance you need on the road, while maintaining fuel efficiency. And the 4-cylinder Camry SE cranks out 179 hp. Plus, this year's 4-cylinder comes with a 6-speed manual or available automatic transmission.

US-VZ09-28-A



V6 ENGINE AND VVT-i

On Camry XLE, SE and LE, the available 3.5-liter DOHC 24-valve dual VVT-i V6 engine pumps out a throbbing 268 horsepower.



6-SPEED AUTOMATIC TRANSMISSION WITH SEQUENTIAL SHIFT

Utilizing 30% fewer parts than the conventional 5-speed transmission, the 6-speed automatic transmission with sequential shift helps save weight. The result? Quicker response and improved performance, while simultaneously increasing fuel efficiency.

US-ICY10-4-A

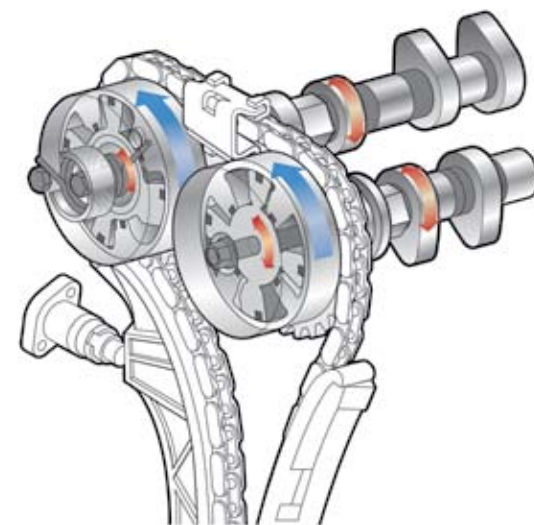

DUAL VARIABLE VALVE TIMING WITH INTELLIGENCE (VVT-i)

Dual Variable Valve Timing with intelligence, or VVT-i, constantly adjusts the valve timing to meet specific driving conditions and deliver optimum performance, fuel economy and lower emissions over a variety of engine speeds. At low engine speeds, the intake valve timing is set to open after the exhaust valve has already closed. At higher speeds, intake valve opening is advanced to overlap with the exhaust valve to promote efficient cylinder filling.

1. 2009 EPA-estimated mileage with manual transmission. Actual mileage will vary.



LE shown in Sandy Beach Metallic with available 16-in. alloy wheels.

Toyota's drive to continually improve is especially evident in the many safety technologies standard on Camry. It comes standard with the Toyota Star Safety System™. This integration of active and passive safety features serves the fundamental aim of helping to protect occupants in the event of a collision, and assisting drivers to avoid accidents in the first place. The Star Safety System™¹ includes Vehicle Stability Control (VSC)², Traction Control (TRAC), Anti-lock Brake System (ABS) with Electronic Brake-force Distribution (EBD) and Brake Assist.³



US-CY10-33-A



DID YOU KNOW?
 A study by the National Highway Traffic Safety Administration showed that in 2007 alone, 15,147 lives were saved by seatbelts (occupants age 5 and older), 2,788 lives were saved by front airbags (occupants age 13 and older), and 382 lives (age 4 and under) were saved by child restraints (child safety seats and lap/shoulder belts).

Demo not intended to replicate actual airbag deployment.

SEVEN AIRBAGS⁴

Standard equipment on every 2010 model Camry is an Advanced Airbag System that includes seven airbags: advanced airbags for the driver and front passenger, front and rear side curtain airbags, front seat-mounted side airbags for the driver and front passenger, and a driver's knee airbag.



US-CY10-35-A

DIRECT TIRE PRESSURE MONITOR SYSTEM (TPMS)⁵

A low-pressure tire may seem innocent enough, but it can lead to big trouble. Camry's Direct Tire Pressure Monitor System (TPMS) provides early notification of critically low tire pressure.

US-CY10-36-A



ELECTRONIC BRAKE-FORCE DISTRIBUTION (EBD) AND BRAKE ASSIST³

This compact actuator is an engineering marvel that works in conjunction with EBD and Brake Assist. It balances brake pressure distribution according to vehicle load and braking conditions, automatically adjusting the amount of brake force applied to each wheel. To help optimize the available traction, EBD can transfer braking front-to-rear or side-to-side.

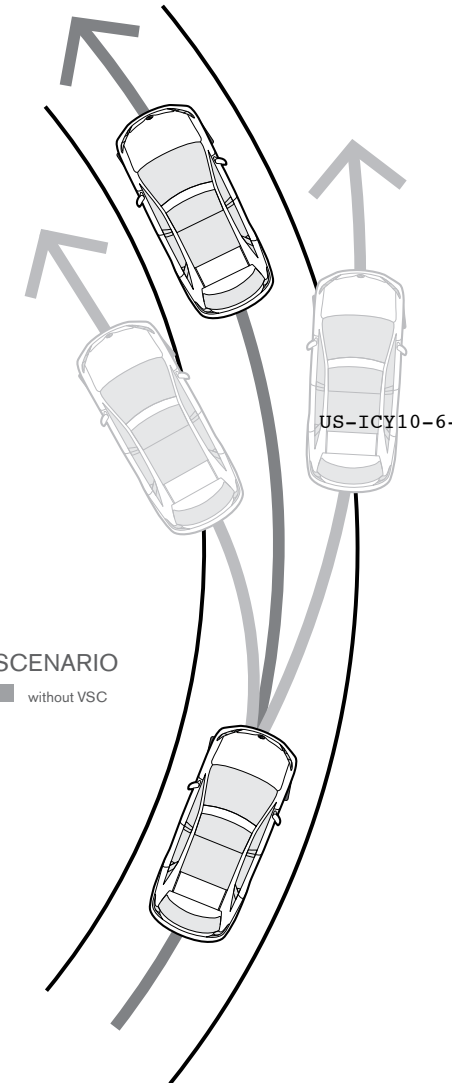

POSSIBLE SCENARIO

■ with VSC ■ without VSC

ANTI-LOCK BRAKE SYSTEM (ABS)

One of the most critical aspects of Camry's prowess as a premium sedan is its performance under uncertain conditions. In the event of hard or sudden braking, Camry's Anti-lock Brake System (ABS) helps maintain vehicle control by automatically releasing and reapplying brake pressure as needed to help prevent wheel lockup.

US-CY10-37-A



VEHICLE STABILITY CONTROL (VSC)² WITH TRACTION CONTROL (TRAC)

New for 2010, every Camry comes standard with Vehicle Stability Control (VSC) with Traction Control (TRAC). VSC counteracts front or rear wheelslip while turning and helps restore driving control. TRAC applies wheel brakes individually and reduces engine output, helping maintain traction on wet, icy, loose or uneven surfaces. It's all about safety.

1. Hybrid includes Vehicle Dynamics Integrated Management (VDIM). See footnote 13 in Hybrid Specifications section.
 2. See footnote 19 in Features section. 3. See footnote 20 in Features section. 4. See footnote 21 in Features section.
 5. See footnote 22 in Features section.

PEOPLE SAFETY ENVIRONMENT FUTURE



US-TM08-137-A



US-TM08-138-A

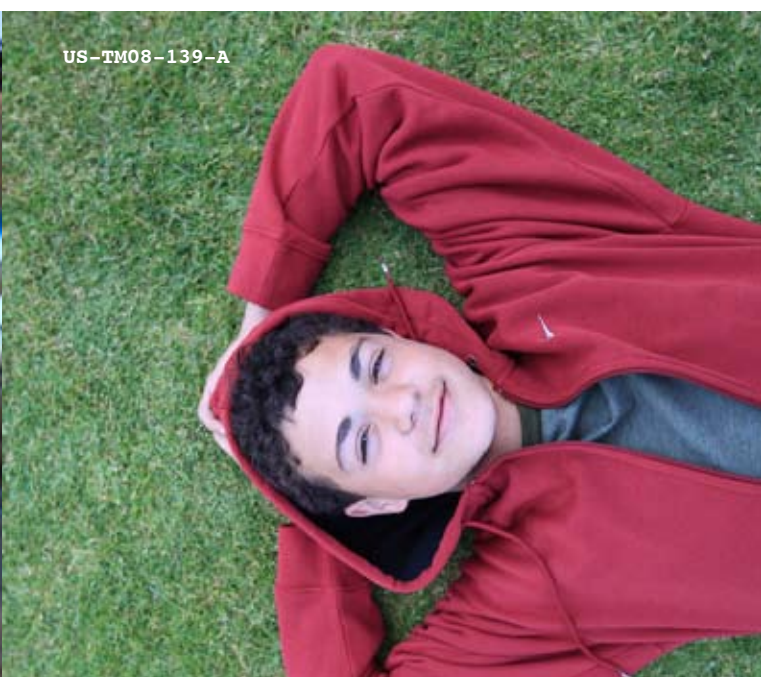

US-TM08-139-A



US-TM08-140-A

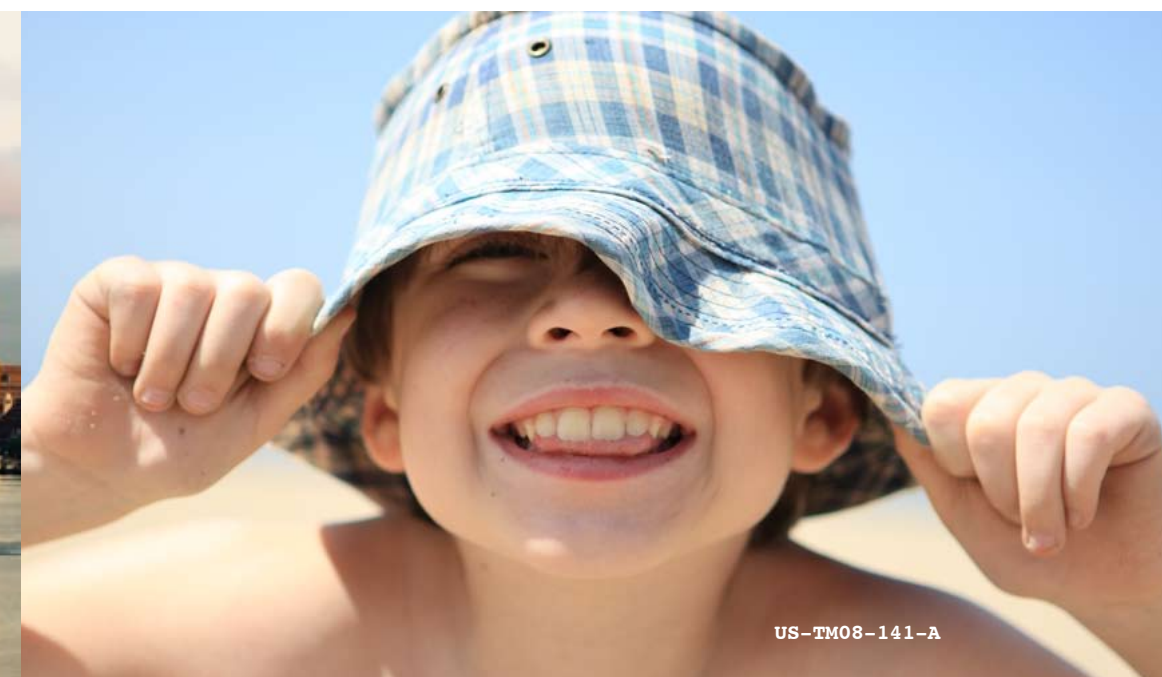

US-TM08-141-A



US-TM08-142-A

There's a lot of work to be done in order to make the future a better one for all of us. At Toyota, we recognize the role we play ultimately can be a very large one. It involves moving forward on many fronts, from education and community to a wide range of initiatives aimed at reducing our environmental footprint. Helping

to make driving safe is one of our top priorities. Since 2004, Toyota has offered a free defensive driving program to more than 10,000 teens and adults in 13 cities. Students learn everything from skid control to the consequences of driving while distracted. For more on our safety programs, visit toyotateendrivers.com

Our philanthropic efforts help civic, educational and social support organizations of all kinds improve our schools, neighborhoods and environment. The Toyota International Teacher Program sends U.S. educators to the Galapagos Islands and Costa Rica to share ideas on environmental stewardship.

Closer to home, we're hard at work on ideas for reducing our own impact on the environment. Our holistic approach involves using energy and resources efficiently, improving air quality, encouraging recycling and being a good neighbor. Since the first-generation Prius was introduced in 2000, we've added Highlander Hybrid

and Camry Hybrid to our hybrid offerings. While our 13 production facilities in the U.S. assemble more than one million vehicles a year, our plants are driving hard toward zero landfill waste. A Toyota dealership in Texas is the first auto dealership in the U.S. to earn LEED¹ Gold certification from the U.S. Green Building Council.

The group also certified our South Campus Sales Headquarters of Toyota Motor Sales, U.S.A., in Torrance, California, as one of the largest "green" buildings in the U.S. To learn more about Toyota, its commitment to the environment and its involvement in local communities, visit toyota.com/whynot

10 FEATURES¹

EXTERIOR	CAMRY	LE	SE	XLE		CAMRY	LE	SE	XLE
Aerodynamic multi-reflector projector-beam headlamps with auto on/off feature	S	S	-	S	Heated outside mirrors	-	-	O⁴/P⁴	S
Aerodynamic multi-reflector projector-beam headlamps with blackout sport trim and auto on/off feature	-	-	S	-	High Solar Energy-Absorbing (HSEA) glass	S	S	S	S
Integrated front fog lamps	-	-	S	S	Washer-linked variable intermittent windshield wipers with mist cycle	S	S	S	S
LED (light-emitting diode) tail, stop and side marker lamps	S	S	S	S	Power tilt/slide moonroof with sliding sunshade	-	P	P	S
16-in. steel wheels with P215/60R16 tires and full wheel covers	S	S	-	-	Blackout sport grille	-	-	S	-
16-in. 7-spoke alloy wheels with P215/60R16 tires	-	O	-	-	Heavy-duty electric rear window defogger with timer	S	S	S	S
17-in. 5-spoke machined alloy wheels with P215/55R17 tires ^{2,3}	-	-	S	-	Dual exhaust (V6 only)	-	S	S⁵	S
16-in. 10-spoke alloy wheels with P215/60R16 tires	-	-	-	S	Chrome-tipped exhaust	-	S⁵	S	S
Dual color-keyed power outside mirrors	S	S	S	S	Color-keyed front and rear underbody spoilers and side rocker panel moldings	-	-	S	-
					Color-keyed rear lip spoiler	-	-	O	-

INTERIOR

Multi-information display with outside temperature, average fuel economy, driving range, average-speed and travel distance since start	-	-	-	S	JBL® AM/FM 6-disc in-dash CD changer with integrated satellite radio, ¹² MP3/WMA playback capability, auxiliary audio jack, USB port with iPod® ¹³ connectivity, hands-free phone capability and music streaming via Bluetooth® ¹⁴ wireless technology, eight speakers in six locations, Vacuum Fluorescent Display and FM diversity reception	-	O⁴	O⁴	S
Multi-function remote keyless entry system with lock, unlock, trunk-release, panic features and illuminated entry	-	S	S	S	Voice-activated DVD navigation system ¹⁵ with integrated backup camera, ¹⁶ JBL® AM/FM 4-disc in-dash CD changer with integrated satellite radio, ¹² MP3/WMA playback capability, auxiliary audio jack, USB port with iPod® ¹³ connectivity, hands-free phone capability and music streaming via Bluetooth® ¹⁴ wireless technology, eight speakers in six locations and FM diversity reception	-	-	O	O
Smart Key System ⁶ with Push Button Start and remote illuminated entry	-	-	O⁴	O	Auto-dimming rearview mirror with compass	-	O⁴	O¹⁷/P⁴	S
Tilt/telescopic adjustable steering wheel with audio controls	S	S	S	S	Illuminated entry	S	S	S	S
Cruise control	S	S	S	S	HomeLink® ¹⁸ universal transceiver	-	-	P⁴	S
4-spoke leather-wrapped steering wheel and wood-grain-style shift lever	-	-	-	S	Power windows with auto up/down and retained-power features with jam protection	S	S	S	S
3-spoke leather-wrapped sport steering wheel and shift lever	-	-	S	-	Power automatic door locks with anti-lockout feature	S	S	S	S
Fabric seat and door trim with integrated armrests and dual front and rear map pockets	S	S	S	-	Optitron meters with speedometer, tachometer, coolant temperature and fuel level gauges; digital odometer and twin tripmeters with outside temperature display	S	S	S	S
Fabric seat and door trim treated with Fraichir™ ⁷ process with integrated armrests and dual front and rear map pockets	-	-	-	S⁸	Blue Optitron sport meters	-	-	S	-
Leather-trimmed seats and door trim with integrated armrests	-	-	O⁴	O⁹	Manually retractable rear window sunshade	-	-	-	S
Heated front seats	-	-	O¹⁰	O¹⁰	Rear personal reading lights	-	-	P	S
Unique Sport fabric seats	-	-	S	-	Hand lever parking brake (manual transmission only)	S	S	S	-
Aluminum doorsills and sport pedals	-	-	S	-	Foot pedal parking brake (automatic transmission only)	S	S	S	S
Metallic-style interior trim with chrome door handle accents	-	S	S	-	Remote hood, trunk and fuel-filler door releases	S	S	S	S
Wood-grain-style interior trim with chrome accents on door handles	-	-	-	S	Dual illuminated visor vanity mirrors	-	P	P	S
Multi-adjustable front bucket seats with adjustable headrests and seatback pockets; manual driver's seat with vertical seat height adjuster and lumbar support	S	-	-	-	Overhead console with maplights and sunglasses holder	S	S	S	S
Multi-adjustable power driver's seat with adjustable headrest, seatback pocket and lumbar support	-	S	S	S	Lockable illuminated glove box	S	S	S	S
Multi-adjustable power front passenger seat	-	-	O¹⁰	S	Digital quartz clock	S	S	S	S
60/40 split fold-down rear seat with security locks, adjustable headrests and center armrest with cup holders	S	S	-	-	Bi-level covered center console with storage	S	S	S	S
40/20/40 split manually reclining rear seats with separate headrests, center armrest with cup holders and locking trunk pass-through	-	-	-	S	Sliding center armrest	-	-	-	S
CFC-free air conditioning with dust and pollen filter	S	S	S	-	Two 12V auxiliary power outlets	S	S	S	S
CFC-free dual zone automatic climate control with dust and pollen filter, Plasmacluster™ ¹¹ ionizer, steering wheel-mounted controls and rear-seat vents	-	-	-	S	Front cup holders	S	S	S	S
AM/FM CD player with satellite radio capability, ¹² MP3/WMA playback capability, auxiliary audio jack, six speakers and in-glass antenna	S	S	S	-	Fold-down rear center armrest with dual cup holders	S	S	S	S
AM/FM CD player with integrated satellite radio, ¹² MP3/WMA playback capability, auxiliary audio jack, USB port with iPod® ¹³ connectivity, hands-free phone capability and music streaming via Bluetooth® ¹⁴ wireless technology, Vacuum Fluorescent Display, six speakers and in-glass antenna	-	O	O	-	Trunk luggage box	S	S	S	S
					Trunk-mounted cargo net	-	-	-	S

1. Toyota strives to build vehicles to match customer interest and thus they typically are built with popular options and option packages. Not all options/packages are available separately and some may not be available in all regions of the country. See toyota.com for information about options/packages commonly available in your area. If you would prefer a vehicle with no or different options, contact your dealer to check for current availability or the possibility of placing a special order. 2. SE available with All-Season tires as a no-cost option. 3. Performance tires are expected to experience greater tire wear than conventional tires. Tire life may be less than 24,000 miles, depending upon driving conditions. 4. Automatic transmission only. 5. Includes 4-cylinder and V6 models. 6. The Smart Key System may interfere with some pacemakers or cardiac defibrillators. If you have one of these medical devices, please talk to your doctor to see if you should deactivate this system. 7. Fraichir™ is a trademark of Seiren Co., Ltd. 8. 4-cylinder only. 9. Standard on V6, available on 4-cylinder. 10. Requires available leather-trimmed seats. 11. Plasmacluster™ is a trademark of Sharp Electronics, Inc. 12. Satellite radio requires compatible receiver and monthly service fee. See your Toyota dealer for further details. Reception of the satellite signal may vary depending on location. All fees and programming subject to change. Subscriptions subject to the terms and conditions available at www.xmradio.com or www.sirius.com. Available only in the 48 contiguous United States. 13. iPod® is a registered trademark of Apple, Inc. All rights reserved. 14. The Bluetooth® technology phones listed on toyota.com have been tested for compatibility with Toyota vehicles. Performance will vary based on phone software version, coverage and your wireless carrier. Phones are warranted by their manufacturer, not Toyota. 15. The navigation system is designed to assist in locating an address or point of interest. XM NavTraffic® requires a monthly service fee and is designed to provide real-time traffic or alternative routes of travel. Discrepancies may be encountered between the system and your actual location. Road system changes may affect the accuracy of the information provided. Rely on your common sense to decide whether to follow a specified route. Detailed coverage not available in every city or roadway. Periodic navigation updates available at an additional cost. See your *Navigation System Owner's Manual* for further details. 16. The backup camera does not provide a comprehensive view of the rear area of the vehicle. You should also look around outside your vehicle and use your mirrors to confirm rearward clearance. Cold weather will limit effectiveness and view may become cloudy. 17. Manual transmission only. 18. HomeLink® is

10 FEATURES (continued)

SAFETY AND CONVENIENCE	CAMRY	LE	SE	XLE		CAMRY	LE	SE	XLE
 Star Safety System™ – includes Enhanced Vehicle Stability Control (VSC) ¹⁹ with cutoff switch + Traction Control (TRAC), Anti-lock Brake System (ABS) with Electronic Brake-force Distribution (EBD) and Brake Assist ²⁰	S	S	S	S	Front and rear crumple zones and side-impact door beams	S	S	S	S
					Direct Tire Pressure Monitor System (TPMS) ²²	S	S	S	S
Driver and front passenger Advanced Airbag System ²¹	S	S	S	S	Energy-absorbing collapsible steering column	S	S	S	S
					Child-protector rear door locks	S	S	S	S
Driver and front passenger front seat-mounted side airbags and front and rear side curtain airbags ²¹	S	S	S	S	LATCH (Lower Anchors and Tethers for Children) for outboard rear seating positions only	S	S	S	S
					Internal trunk-release handle	S	S	S	S
Driver's knee airbag ²¹	S	S	S	S	Battery-saver feature – deactivates interior lights after 20 minutes	S	S	S	S
3-point front seatbelts with adjustable shoulder anchors and driver-side Emergency Locking Retractor (ELR), front passenger Automatic/Emergency Locking Retractor (ALR/ELR)	S	S	S	S	Daytime Running Lights (DRL) with off mode	S	S	S	S
3-point rear seatbelts with Automatic/Emergency Locking Retractors (ALR/ELR) for all passengers	S	S	S	S	Engine immobilizer ²³	S	S	S	-
Outboard rear seatbelt comfort guides	S	S	S	S	Engine immobilizer with alarm ²³	-	-	-	S

S = Standard **O = Optional** **- = Not Available** **P = Feature is available as part of an option package.**

10 PACKAGES AND OPTIONS

PACKAGES

CAMRY

None

LE

Moonroof Package – includes power tilt/slide moonroof with sliding sunshade, dual illuminated visor vanity mirrors and rear personal reading lights

SE

Sport Leather Package – includes heated front seats, leather-trimmed seats and door trim with integrated armrests and dual front and rear map pockets, and dual color-keyed, heated power outside mirrors⁴
Sport Convenience Package – includes HomeLink®¹⁸ universal transceiver and auto-dimming rearview mirror with compass⁴

Moonroof Package – includes power tilt/slide moonroof with sliding sunshade, dual illuminated visor vanity mirrors and rear personal reading lights

XLE

None

OPTIONS

CAMRY

None

LE

Auto-dimming rearview mirror with compass⁵
16-in. 7-spoke alloy wheels with P215/60R16 tires
AM/FM CD player with integrated satellite radio,¹² MP3/WMA playback capability, auxiliary audio jack, USB port with iPod®¹³ connectivity, hands-free phone capability and music streaming via Bluetooth®¹⁴ wireless technology, in-glass antenna, six speakers and Vacuum Fluorescent Display

JBL®⁴ AM/FM 6-disc in-dash CD changer with integrated satellite radio,¹² MP3/WMA playback capability, auxiliary audio jack, USB port with iPod®¹³ connectivity, hands-free phone capability and music streaming via Bluetooth®¹⁴ wireless technology, eight speakers in six locations, Vacuum Fluorescent Display and FM diversity reception

SE

Color-keyed rear lip spoiler
AM/FM CD player with integrated satellite radio,¹² MP3/WMA playback capability, auxiliary audio jack, USB port with iPod®¹³ connectivity, hands-free phone capability and music streaming via Bluetooth®¹⁴ wireless technology, in-glass antenna, six speakers and Vacuum Fluorescent Display

JBL®⁴ AM/FM 6-disc in-dash CD changer with integrated satellite radio,¹² MP3/WMA playback capability, auxiliary audio jack, USB port with iPod®¹³ connectivity, hands-free phone capability and music streaming via Bluetooth®¹⁴ wireless technology, eight speakers in six locations, Vacuum Fluorescent Display and FM diversity reception

Voice-activated DVD navigation system¹⁵ with integrated backup camera,¹⁶ JBL® AM/FM 4-disc in-dash CD changer with integrated satellite radio,¹² MP3/WMA playback capability, auxiliary audio jack, USB port with iPod®¹³ connectivity, hands-free phone capability and music streaming via Bluetooth®¹⁴ wireless technology, eight speakers in six locations and FM diversity reception

Auto-dimming rearview mirror with compass¹⁷

Heated outside mirrors⁴

Sport leather-trimmed seats and door trim with integrated armrests and front passenger power seat⁴

Smart Key System^{4,6} with Push Button Start

XLE

Leather-trimmed seats and door trim with integrated armrests⁹

Heated front seats¹⁰

Smart Key System⁶ with Push Button Start

Voice-activated DVD navigation system¹⁵ with integrated backup camera,¹⁶ JBL® AM/FM 4-disc in-dash CD changer with integrated satellite radio,¹² MP3/WMA playback capability, auxiliary audio jack, USB port with iPod®¹³ connectivity, hands-free phone capability and music streaming via Bluetooth®¹⁴ wireless technology, eight speakers in six locations and FM diversity reception

a registered trademark of Johnson Controls, Inc. 19. Vehicle Stability Control (VSC) is an electronic system designed to help the driver maintain vehicle control under adverse conditions. It is not a substitute for safe driving practices. Factors including speed, road conditions and driver steering input can all affect whether VSC will be effective in preventing a loss of control. Please see your *Owner's Manual* for further details. 20. Brake Assist is designed to help the driver take full advantage of the benefits of ABS. It is not a substitute for safe driving practices. Braking effectiveness also depends on proper brake-system maintenance and tire and road conditions. 21. All the airbag (AB) systems are Supplemental Restraint Systems. All ABs (if installed) are designed to inflate only under certain conditions and in certain types of severe collisions: frontal and knee ABs typically inflate in frontal collisions; side and side curtain ABs in side collisions; Roll-Sensing Curtain ABs at a severe tilt degree, roll or lateral G-force. In all other accidents, the ABs will not inflate. To decrease the risk of injury from an inflating AB, always wear seatbelts, sit upright in the middle of the seat as far back as possible and do not lean against the seat. Do not put objects in front of an AB or around the seatback. Do not use a rearward-facing child seat in any front passenger seat. The force of an inflating AB may cause serious injury or death. See your *Owner's Manual* for further information/warnings. 22. The Toyota Tire Pressure Monitor alerts the driver when tire pressure is critically low. For optimal tire wear and performance, tire pressure should be checked regularly with a gauge; do not rely solely on the monitor system. See your *Owner's Manual* for details. 23. The engine immobilizer is a state-of-the-art anti-theft system. When you insert your key into the ignition switch, the key transmits an electronic code to the vehicle. The engine will only start if the code in the transponder chip inside the key matches the code in the vehicle's immobilizer. Because the transponder chip is embedded in the key, it can be costly to replace. If you lose a key, your Toyota dealer can help, or you can find a qualified independent locksmith to replace your key or perform high-security key services at www.alcoa.org

10 SPECIFICATIONS

MECHANICAL/PERFORMANCE	CAMRY, LE 4-CYLINDER	LE V6	SE 4-CYLINDER	SE V6	XLE 4-CYLINDER	XLE V6
Engine	2.5-liter DOHC 16-valve Dual VVT-i 4-cylinder; 169 hp ¹ @ 6000 rpm/167 lb.-ft. ¹ @ 4100 rpm	3.5-liter DOHC 24-valve Dual VVT-i V6; 268 hp @ 6200 rpm/248 lb.-ft. @ 4700 rpm	2.5-liter DOHC 16-valve Dual VVT-i 4-cylinder; 179 hp @ 6000 rpm/171 lb.-ft. @ 4100 rpm	3.5-liter DOHC 24-valve Dual VVT-i V6; 268 hp @ 6200 rpm/248 lb.-ft. @ 4700 rpm	2.5-liter DOHC 16-valve Dual VVT-i 4-cylinder; 169 hp ¹ @ 6000 rpm/167 lb.-ft. ¹ @ 4100 rpm	3.5-liter DOHC 24-valve Dual VVT-i V6; 268 hp @ 6200 rpm/248 lb.-ft. @ 4700 rpm
Ignition	Electronic, with Toyota Direct Ignition (TDI)					
Transmission	6-speed manual overdrive	NA	Standard	NA	NA	NA
	6-speed electronically controlled automatic overdrive with intelligence and sequential shift (ECT-i)	Standard	Available	Standard	Standard	Standard
Drivetrain	Front engine, front-wheel drive					
Body construction	Unitized body with front and rear vibration-dampening sub-frames					
Suspension	MacPherson strut front suspension with gas-filled shock absorbers and stabilizer bar; dual-link independent MacPherson strut rear suspension with gas-filled shock absorbers and stabilizer bar (SE adds sport-tuned shock absorbers and springs, strut tower and trunk-mounted braces)					
Steering	Variable-assist power rack-and-pinion					
Turning circle diameter, curb to curb (ft.)	36.1	36.1	36.1	36.1	36.1	36.1
Brakes	Power-assisted ventilated front/solid rear disc					
4-channel 3-sensor Anti-lock Brake System (ABS) with Electronic Brake-force Distribution (EBD) and Brake Assist ²	Standard	Standard	Standard	Standard	Standard	Standard
Vehicle Stability Control (VSC) ³ with Traction Control (TRAC)	Standard	Standard	Standard	Standard	Standard	Standard
EXTERIOR DIMENSIONS (in.)						
Overall height, unloaded	57.9	57.9	57.7	57.7	57.9	57.9
Overall width	71.7	71.7	71.7	71.7	71.7	71.7
Overall length	189.2	189.2	189.2	189.2	189.2	189.2
Wheelbase	109.3	109.3	109.3	109.3	109.3	109.3
Ground clearance	5.5	5.3	5.3	5.1	5.5	5.3
Track (front/rear)	62.0/61.6	62.0/61.6	62.0/61.6	62.0/61.6	62.0/61.6	62.0/61.6
Coefficient of drag (Cd)	0.28	0.28	0.28	0.28	0.28	0.28
INTERIOR DIMENSIONS front/rear (in.)						
Head room						
without moonroof	38.8/37.8	38.8/37.8	38.8/37.8	38.8/37.8	NA	NA
with moonroof	37.9/37.4 ⁴	37.9/37.4	37.9/37.4	37.9/37.4	37.9/37.4	37.9/37.4
Shoulder room	57.8/56.9	57.8/56.9	57.8/56.9	57.8/56.9	57.8/56.9	57.8/56.9
Hip room	54.6/53.9	54.6/53.9	54.6/53.9	54.6/53.9	54.6/53.9	54.6/53.9
Leg room	41.7/38.3	41.7/38.3	41.7/38.3	41.7/38.3	41.7/38.3	41.7/38.3
Seating capacity	5	5	5	5	5	5
WEIGHTS AND CAPACITIES						
Curb weight, manual/automatic (lb.)	3263/3307	NA/3461	3285/3329	NA/3483	NA/3373	NA/3516
EPA passenger volume (cu. ft.)	101.4	101.4	101.4	101.4	101.4	101.4
Luggage capacity, rear seatbacks up (cu. ft.)	15.0	15.0	14.5	14.5	14.5	14.5
Fuel tank (gal.)	18.5	18.5	18.5	18.5	18.5	18.5
TIRES						
Size	P215/60R16	P215/60R16	P215/55R17	P215/55R17	P215/60R16	P215/60R16
Type	All-Season	All-Season	Performance ⁵	Performance ⁵	All-Season	All-Season
MILEAGE ESTIMATES (mpg city/highway)⁶						
Manual transmission	22/33	NA	22/33	NA	NA	NA
Automatic transmission	22/32	19/28	22/32	19/28	22/32	19/28
TOYOTA FINANCIAL SERVICES*						



Get more with the Toyota Rewards Visa – the card that earns as you spend. Because the more you use it, the more you get. Turn everything you buy into points to redeem toward service, parts, accessories or an eligible vehicle purchase or lease; earn 5 points for every \$1 spent at participating Toyota dealers and 1 point for every \$1 spent everywhere else Visa is accepted.^{1,2} Enjoy all these benefits without an annual fee and without an annual cap on points earned or redeemed. Visit www.toyotarewardsvisa.com or call 866-614-8845 for complete details. For more information on Toyota Financial Services' competitive financing, visit www.toyotafinancial.com

¹On approved credit. Terms, conditions and restrictions apply and are fully described in the Toyota Rewards Visa Cardmember Agreement and the Toyota Rewards Program Terms and Conditions. Points redemption not available at Hawaii dealerships. Points cannot be redeemed for cash. ²Your Toyota dealer may impose restrictions on the use of credit cards related to vehicle purchases or leases. *The creditor and issuer of the Toyota Rewards Visa is Toyota Financial Savings Bank. Toyota Financial Services is a service mark used by Toyota Motor Credit Corporation and Toyota Financial Savings Bank. Financing is available to qualified customers through participating Toyota dealers and Toyota Motor Credit Corporation.

10 COMBINATIONS

COLOR



Black



Blue Ribbon Metallic



Spruce Mica^{4,7}



Aloe Green Metallic^{4,7,8}



Barcelona Red Metallic⁴



Sandy Beach Metallic^{7,8}



Magnetic Gray Metallic⁴



Classic Silver Metallic⁹



Super White

FABRIC/LEATHER



Camry and LE fabric in Ash



Available SE leather in Ash

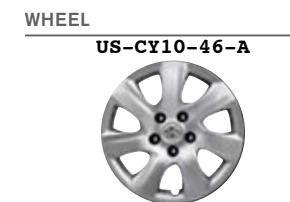

Camry and LE standard 16-in. steel wheel with full wheel cover



LE available 16-in. 7-spoke alloy wheel

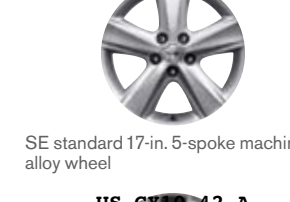

SE standard 17-in. 5-spoke machined alloy wheel

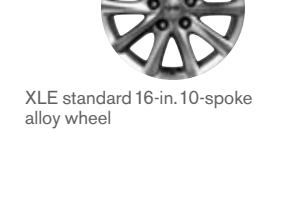

XLE standard 16-in. 10-spoke alloy wheel



Camry and LE fabric in Bisque

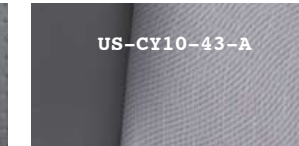

XLE fabric¹⁰ in Ash

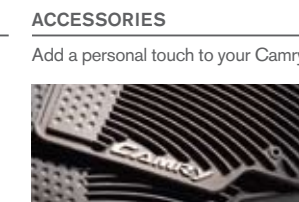

All-weather floor mats

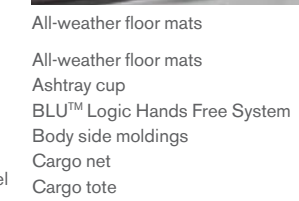

All-weather floor mats



Doorsill enhancement

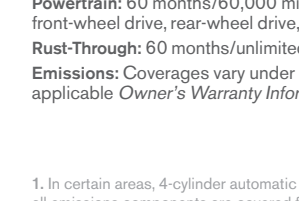

Rear lip spoiler



SE fabric in Dark Charcoal



XLE fabric¹⁰ in Bisque

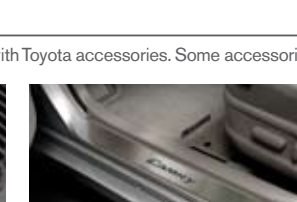

All-weather floor mats

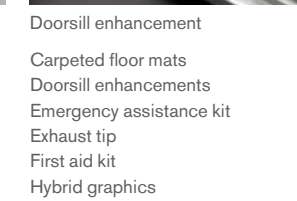

Doorsill enhancement

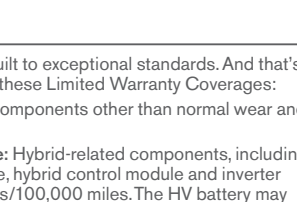

Molded dash appliqué

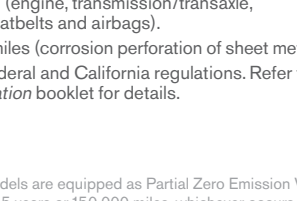

Molded dash appliqué



SE fabric in Ash



Available XLE leather¹¹ in Ash

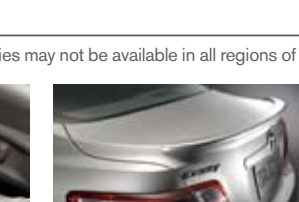

Doorsill enhancement

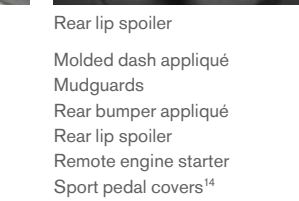

Carpeted floor mats

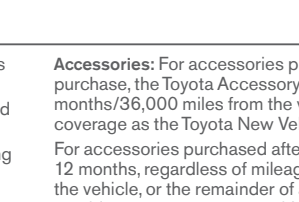

Doorsill enhancements

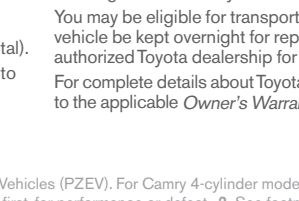

Emergency assistance kit



Available SE leather in Dark Charcoal



Available XLE leather¹¹ in Bisque

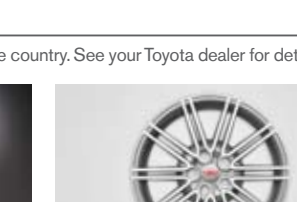

Doorsill enhancement

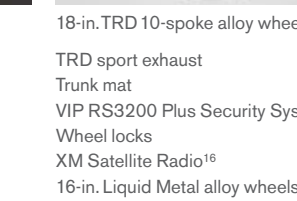

Doorsill enhancements

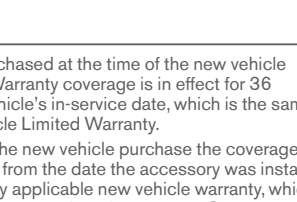

Emergency assistance kit

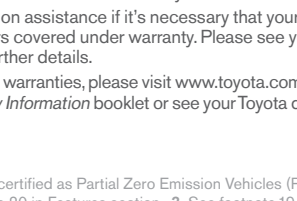

Exhaust tip

1. In certain areas, 4-cylinder automatic models are equipped as Partial Zero Emission Vehicles (PZEV). For Camry 4-cylinder models certified as Partial Zero Emission Vehicles (PZEV), all emissions components are covered for 15 years or 150,000 miles, whichever occurs first, for performance or defect. 2. See footnote 20 in Features section. 3. See footnote 19 in Features section. 4. Not available on Camry grade. 5. See footnotes 2 and 3 in Features section. 6. 2009 EPA-estimated mileage. Actual mileage will vary. 7. Not available on SE. 8. Not available with Ash interior. 9. Not available with Bisque interior. 10. 4-cylinder only. 11. Standard on V6, available on 4-cylinder. 12. See footnote 3 in Features section. 13. See footnote 13 in Features section. 14. Automatic transmission only. 15. Available for vehicles with factory remote keyless entry. 16. See footnote 12 in Features section.

10 HYBRID FEATURES¹

EXTERIOR

Aerodynamic multi-reflector projector-beam headlamps with auto on/off feature	S	Acoustic noise-reducing front windshield	S
Blue-tinted headlamp bezels	S	High Solar Energy-Absorbing (HSEA) glass	S
Integrated front fog lamps	O	Washer-linked variable intermittent windshield wipers with mist cycle	S
16-in. steel wheels with P215/60R16 tires and full wheel covers	S	Power tilt/slide moonroof with sliding sunshade	P ²
16-in. 10-spoke aluminum alloy wheels with P215/60R16 tires	P ²	Heavy-duty electric rear window defogger with timer	S
Dual color-keyed power outside mirrors	S	Chrome-tipped exhaust	S
Heated outside mirrors	O/P ²		

INTERIOR

Multi-function remote keyless entry system with lock, unlock, trunk-release and panic features	S	Power windows with auto up/down and retained-power features with jam protection	S
Smart Key System ³ with Push Button Start and remote illuminated entry	S	Power automatic door locks with anti-lockout feature	S
AM/FM CD player with satellite radio capability, ⁴ MP3/WMA playback capability, auxiliary audio jack, six speakers and in-glass antenna	S	CFC-free dual zone automatic climate control with electric compressor and Plasmacluster™ ¹¹ ionizer and rear-seat vents	S
JBL® AM/FM 6-disc in-dash CD changer with integrated satellite radio, ⁴ MP3/WMA playback capability, auxiliary audio jack, USB port with iPod® ⁵ connectivity, hands-free phone capability and music streaming via Bluetooth® ⁶ wireless technology, eight speakers in six locations, Vacuum Fluorescent Display and FM diversity reception	P ²	Tilt/telescopic adjustable steering wheel with audio and climate controls	S
Voice-activated DVD navigation system ⁷ with integrated backup camera, ⁸ JBL® AM/FM 4-disc in-dash CD changer with integrated satellite radio, ⁴ MP3/WMA playback capability, auxiliary audio jack, USB port with iPod® ⁵ connectivity, hands-free phone capability and music streaming via Bluetooth® ⁶ wireless technology, eight speakers in six locations and FM diversity reception	P ²	Leather-wrapped steering wheel and shift knob	P ²
Multi-information display with ECO Drive Level, hybrid system energy flow, outside temperature, average fuel economy, driving range, average speed and travel distance since start	S	Day/night rearview mirror	S
Fabric seat and door trim treated with Fraichir™ ⁹ process, with integrated armrests and dual front and rear map pockets	S	Auto-dimming rearview mirror with compass	P ²
Leather-trimmed seats and door trim with integrated armrests, sliding center console, front passenger power seat and wood-grain-style interior trim	P ²	Dual illuminated visor vanity mirrors	P ²
Heated front seats	P ^{2,10}	Overhead console with maplights and sunglasses holder	S
Metallic-style interior trim with chrome door handle accents	S	HomeLink® ¹² universal transceiver	P ²
Multi-adjustable power driver's seat with adjustable headrest, seatback pocket and lumbar support	S	Rear personal reading lights	P ²
60/40 split fold-down rear seat with security locks, adjustable headrests and seatbelt positioning clips	S	Foot pedal parking brake	S
Optitron meters with speedometer, instant mpg, coolant temperature and fuel level gauges; digital odometer and twin tripmeters	S	Remote hood, trunk and fuel-filler door releases	S
Cruise control	S	Illuminated entry	S

SAFETY AND CONVENIENCE

 Star Safety System™ with Vehicle Dynamics Integrated Management (VDIM) ¹³ – includes Vehicle Stability Control (VSC) ¹⁴ with cutoff switch + Traction Control (TRAC), Anti-lock Brake System (ABS) with Electronic Brake-force Distribution (EBD) and Brake Assist ¹⁵	S	Direct Tire Pressure Monitor System (TPMS) ¹⁷	S
Driver and front passenger Advanced Airbag System ¹⁶	S	Energy-absorbing collapsible steering column	S
Driver and front passenger front seat-mounted side airbags and front and rear side curtain airbags ¹⁶	S	Child-protector rear door locks	S
Driver's knee airbag ¹⁶	S	LATCH (Lower Anchors and Tethers for Children) for outboard rear seating positions only	S
3-point front seatbelts with adjustable shoulder anchors and driver-side Emergency Locking Retractor (ELR), front passenger Automatic/Emergency Locking Retractor (ALR/ELR)	S	Internal trunk-release handle	S
3-point rear seatbelts with Automatic/Emergency Locking Retractors (ALR/ELR) for all passengers	S	Battery-saver feature – deactivates interior lights after 20 minutes	S
Outboard rear seatbelt comfort guides	S	Daytime Running Lights (DRL) with off mode	S
Front and rear crumple zones and side-impact door beams	S	Engine immobilizer ¹⁶	S

10 HYBRID PACKAGES AND OPTIONS

Moonroof Package² – includes power tilt/slide moonroof with sliding sunshade, dual illuminated visor vanity mirrors and rear personal reading lights		Upgrade Package with DVD Navigation⁷ – includes 16-in. 10-spoke aluminum alloy wheels with P215/60R16 tires, voice-activated DVD navigation system ⁷ with integrated backup camera, ⁸ JBL® AM/FM 4-disc in-dash CD changer with integrated satellite radio, ⁴ MP3/WMA playback capability, auxiliary audio jack, USB port with iPod® ⁵ connectivity, hands-free phone capability and music streaming via Bluetooth® ⁶ wireless technology, eight speakers in six locations and FM diversity reception, leather-wrapped steering wheel and shift knob, auto-dimming rearview mirror with compass and HomeLink® ¹² universal transceiver
Comfort and Convenience Package^{2, 16} – includes heated front seats and outside mirrors		Heated outside mirrors ²
Leather Package² – includes leather-trimmed seats and door trim with integrated armrests, sliding center console, front passenger power seat and wood-grain-style interior trim		Integrated front fog lamps
Upgrade Package – includes 16-in. 10-spoke aluminum alloy wheels with P215/60R16 tires, JBL® AM/FM 6-disc in-dash CD changer with integrated satellite radio, ⁴ MP3/WMA playback capability, auxiliary audio jack, USB port with iPod® ⁵ connectivity, hands-free phone capability and music streaming via Bluetooth® ⁶ wireless technology, eight speakers in six locations, Vacuum Fluorescent Display, FM diversity reception, leather-wrapped steering wheel and shift knob, auto-dimming rearview mirror with compass and HomeLink® ¹² universal transceiver		

S = Standard O = Optional P = Feature is available as part of an option package.

10 HYBRID SPECIFICATIONS

MECHANICAL/PERFORMANCE

Hybrid System Net Power	187 hp (140 kW)
Gasoline Engine 2.4-liter DOHC 16-valve VVT-i 4-cylinder Hybrid 147 hp @ 6000 rpm/138 lb.-ft. @ 4400 rpm	
Ignition	Electronic, with Toyota Direct Ignition (TDI)
Electric Motor	
Power output	199 lb.-ft. @ 0–1500 rpm (105 kW @ 4500 rpm)
Motor type	Permanent magnet AC synchronous motor
Voltage	650V maximum
Traction Battery	
Power output	40 hp (30 kW)
Type	Sealed Nickel-Metal Hydride (Ni-MH) ¹⁹
Voltage	244.8V
Transmission	Electronically controlled continuously variable transmission (ECVT)
Suspension	MacPherson strut front suspension with gas-filled shock absorbers and stabilizer bar; dual-link independent MacPherson strut rear suspension with gas-filled shock absorbers and stabilizer bar
Steering	Electric Power Steering (EPS) rack-and-pinion with electric power-assist
Turning circle diameter, curb to curb (ft.)	36.1
Brakes	Power-assisted ventilated front/solid rear discs with Anti-lock Brake System (ABS) and integrated regenerative braking

EXTERIOR DIMENSIONS (in.)

Overall height, unloaded	57.5
Overall width	71.7
Overall length	189.2
Wheelbase	109.3
Ground clearance	5.9
Track (front/rear)	62.0/61.6
Coefficient of drag (Cd)	0.27

INTERIOR DIMENSIONS front/rear (in.)

Head room	
without moonroof	38.8/37.8
with moonroof	37.9/37.4
Shoulder room	57.8/56.7
Hip room	54.6/53.9
Leg room	41.6/38.3
Seating capacity	5

WEIGHTS AND CAPACITIES

Curb weight (lb.)	3680
EPA passenger volume (cu. ft.)	101.4
Luggage capacity, rear seatbacks up (cu. ft.)	10.6
Fuel tank (gal.)	17.2

TIRES

Size	P215/60R16
Type	All-Season

MILEAGE ESTIMATES (mpg city/highway)²⁰

ECVT transmission	33/34
-------------------	-------

Some vehicles are shown with available equipment. Seatbelts should be worn at all times. For details on vehicle specifications, standard features and available equipment in your area, contact your Toyota dealer. A vehicle with particular equipment may not be available at the dealership. Ask your Toyota dealer to help locate a specifically equipped vehicle. All information presented herein is based on data available at the time of printing, is subject to change without notice and pertains specifically to mainland U.S.A. vehicles only.

10 HYBRID COMBINATIONS

COLOR



Black



Barcelona Red Metallic



Blue Ribbon Metallic



Sandy Beach Metallic²¹



Blue Whisper Mica



Magnetic Gray Metallic



Spruce Mica



Classic Silver Metallic²²



Aloe Green Metallic²¹



Super White

WHEEL

US-CY10-46-A



Standard 16-in. steel wheel with full wheel cover

US-CY10-41-A



Available 16-in. 10-spoke aluminum alloy wheel

1. See footnote 1 in Features section. 2. Requires Upgrade Package. 3. See footnote 6 in Features section. 4. See footnote 12 in Features section. 5. See footnote 13 in Features section. 6. See footnote 14 in Features section. 7. See footnote 15 in Features section. 8. See footnote 16 in Features section. 9. Fraichir™ is a trademark of Seiren Co., Ltd. 10. Requires Comfort and Convenience Package and Leather Package. 11. Plasmacluster™ is a trademark of Sharp Electronics, Inc. 12. HomeLink® is a registered trademark of Johnson Controls, Inc. 13. Vehicle Dynamics Integrated Management (VDIM) is an electronic system designed to help the driver maintain vehicle control under adverse conditions. It is not a substitute for safe driving practices. Factors including speed, road conditions and driver steering input can all affect whether VDIM will be effective in preventing a loss of control. Please see your *Owner's Manual* for further details. 14. See footnote 19 in Features section. 15. See footnote 20 in Features section. 16. See footnote 21 in Features section. 17. See footnote 22 in Features section. 18. Requires Leather Package. 19. Hybrid vehicle battery expected life is 150,000 miles based on laboratory bench testing. 20. See footnote 6 in Combinations section. 21. Not available with Ash interior. 22. Not available with Bisque interior.



For Toyota Mobility program details, go to www.toyota.com/mobility or call the Toyota Customer Assistance Center at 1-800-331-4331

FABRIC/LEATHER



Fabric in Ash



Fabric in Bisque



Available leather in Ash

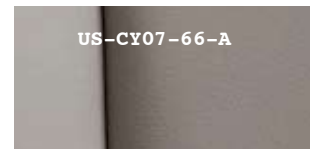

Available leather in Bisque

